

PART NUMBER	ENGINEERING NUMBER	MOUNT OPTION	PLATING	MAT'L.
39-31-1032	5569-03A4-BL	4	BLANK	BL
39-30-3031	5569-03A3	3	BLANK	BLANK
39-30-4039	5569-03A3GS2	3	15 GOLD	
39-30-4037	5569-03A3GS	3	30 GOLD	
39-30-3033	5569-03A3G	3	30 GOLD	
39-30-3035	5569-03A4	4	BLANK	
39-30-4033	5569-03A4GS2	4	15 GOLD	
39-30-4031	5569-03A4GS	4	30 GOLD	
39-30-3037	5569-03A4G	4	30 GOLD	
39-30-6039	5569-03A3S	3	TIN/NICKEL	
39-30-7031	5569-03A4S	4	TIN/NICKEL	BLANK
39-30-3032	5569-03A3-210	3	BLANK	210
39-30-5030	5569-03A3GS2-210	3	15 GOLD	
39-30-4038	5569-03A3GS-210	3	30 GOLD	
39-30-3034	5569-03A3G-210	3	30 GOLD	
39-30-3036	5569-03A4-210	4	BLANK	
39-30-4034	5569-03A4GS2-210	4	15 GOLD	
39-30-4032	5569-03A4GS-210	4	30 GOLD	
39-30-4030	5569-03A4G2-210	4	15 GOLD	
39-30-3038	5569-03A4G-210	4	30 GOLD	
39-30-7030	5569-03A3S-210	3	TIN/NICKEL	
39-30-7032	5569-03A4S-210	4	TIN/NICKEL	
50-34-8577	5569-03A4MS-210	4	MATTE TIN	210
NO E.D.P.	5569-03A5GS2	5	15 GOLD	BLANK
NO E.D.P.	5569-03A5GS	5	30 GOLD	BLANK
NO E.D.P.	5569-03A5MS	5	TIN/NICKEL	BLANK
NO E.D.P.	5569-03A5GS2-210	5	15 GOLD	210
NO E.D.P.	5569-03A5GS-210	5	30 GOLD	210
39-34-3037	5569-03A5MS-210	5	TIN/NICKEL	210

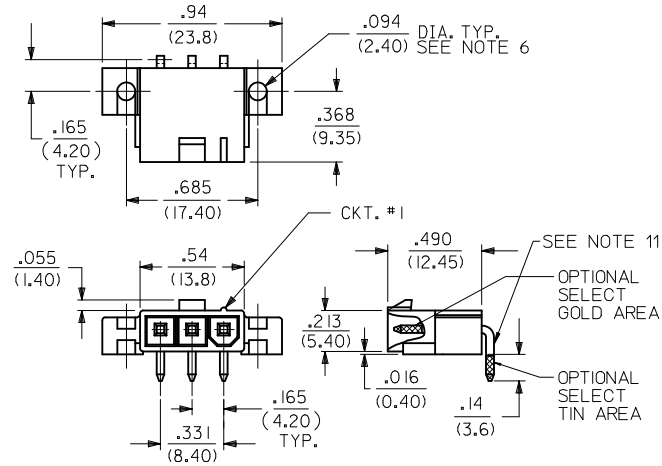

RIGHT ANGLE HEADER
(SCREW MOUNT)

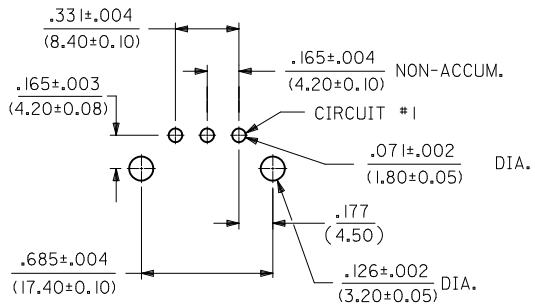

RECOMMENDED HOLE LAYOUT FOR
.070/(1.78) MAX. THICK P.C. BOARD
VIEWED FROM COMPONENT SIDE

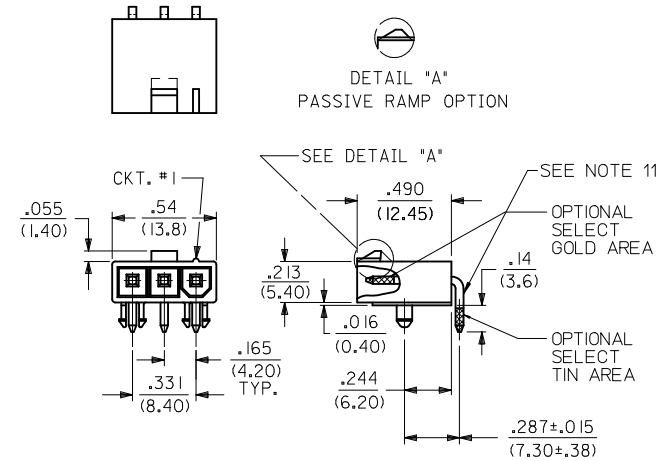

RIGHT ANGLE HEADER
(PEG MOUNT)

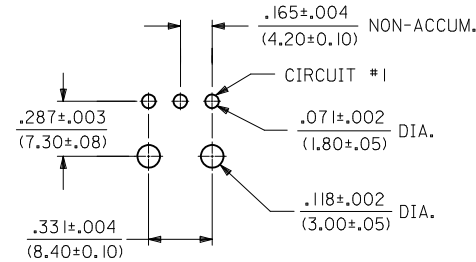

RECOMMENDED HOLE LAYOUT FOR
.070/(1.78) MAX. THICK P.C. BOARD
VIEWED FROM COMPONENT SIDE

NOTES:

- 1) HOUSING MATERIAL:
"BLANK" = NYLON 6/6, U.L. 94V-2, COLOR: NATURAL.
210 = NYLON 6/6, U.L. 94V-0, COLOR: NATURAL.
BL = NYLON 6/6, U.L. 94V-2, COLOR: BLACK.
TERMINAL MATERIAL: BRASS, ALLOY
- 2) TERMINAL PLATING:
"BLANK" S, MS - .000100/(0.00254) MIN. MATTE TIN OVER
.000050/(0.00127) MIN. NICKEL
G, GS - .000030/(.00076) MIN. SELECT GOLD, .000100/(.00254) MIN. SELECT MATTE TIN OVER .000050/(.00127) MIN. NICKEL OVERALL.
G2, GS2 - .000015/(.00038) MIN. SELECT GOLD, .000100/(.0254) MIN. SELECT MATTE TIN OVER .000050/(.00127) MIN. NICKEL OVERALL.
- 3) PRODUCT SPECIFICATION: PS-5556-001
- 4) PACKAGING SPECIFICATION: PK-5569-002
- 5) PART MATES WITH MOLEX RECEPTACLE #5557.
- 6) PART IS DESIGNED FOR USE WITH 4 - 40 OR M3 SCREWS.
- 7) DISCOLORATION IN THE BANDOLIER CARRIER AREA OF THE PIN IS INHERENT TO THE PLATING PROCESS AND IS DUE TO THE MASKING EFFECT OF THE CARRIER. THIS DISCOLORATION IS IN A NON-FUNCTIONAL AREA OF THE PIN AND WILL NOT AFFECT THE PERFORMANCE OF THE HEADER ASSEMBLY.
- 8) CONNECTORS ARE NOT BE MATED OR UNMATED WHILE CIRCUITS ARE LIVE.
- 9) PARTS ARE NOT DESIGNED FOR CURRENT SHARING.
- 10) PART CONFORMS TO CLASS "B" REQUIREMENTS OF "COSMETIC SPECIFICATION PS-45499-002."
- 11) FORMING MARKS ON PINS ARE ACCEPTABLE

LEGEND

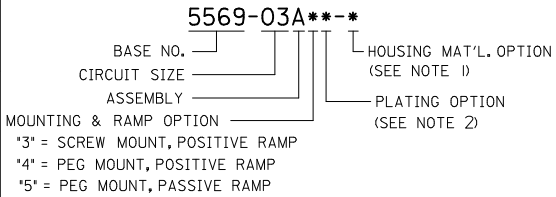

CHANGE PLATING EC NO: UCP2012-0155 DRAWN: NGUYEN 2011/07/22 CHKD: JIBELL 2011/07/22 APPR: FSM/TH 2011/10/28	QUALITY SYMBOLS ▽=0 ▽=0 ▽=0	GENERAL TOLERANCES (UNLESS SPECIFIED)		DIMENSION STYLE IN/MM		SCALE 1:1	DESIGN UNITS METRIC	THIRD ANGLE PROJECTION	
		4 PLACES ± --- ± ---		DRAWN BY DATE GEP 9/20/90		TITLE RIGHT ANGLE HEADER ASSY, 3 CKT., SINGLE ROW, MINI-FIT JR. SERIES			
		3 PLACES ± --- ± .010		CHECKED BY DATE RJF 9/20/90		MOLEX MOLEX INCORPORATED			
2 PLACES ± 0.25 ± .015		APPROVED BY DATE RAS 9/20/90		MATERIAL NO. SEE CHART		DOCUMENT NO. SDA-5569-03A**		SHEET NO. 1 OF 1	
1 PLACE ± 0.38 ± ---		ANGULAR ± 3°		DRAFT WHERE APPLICABLE MUST REMAIN WITHIN DIMENSIONS		THIS DRAWING CONTAINS INFORMATION THAT IS PROPRIETARY TO MOLEX INCORPORATED AND SHOULD NOT BE USED WITHOUT WRITTEN PERMISSION			