

THIS DRAWING IS UNPUBLISHED. RELEASED FOR PUBLICATION
 © COPYRIGHT - By - ALL RIGHTS RESERVED.

LOC	DIST	REVISIONS					
		P	LTR	DESCRIPTION	DATE	DWN	APVD
G	14		D1	REVISED PER ECO-12-008537	07MAY12	KH	DR

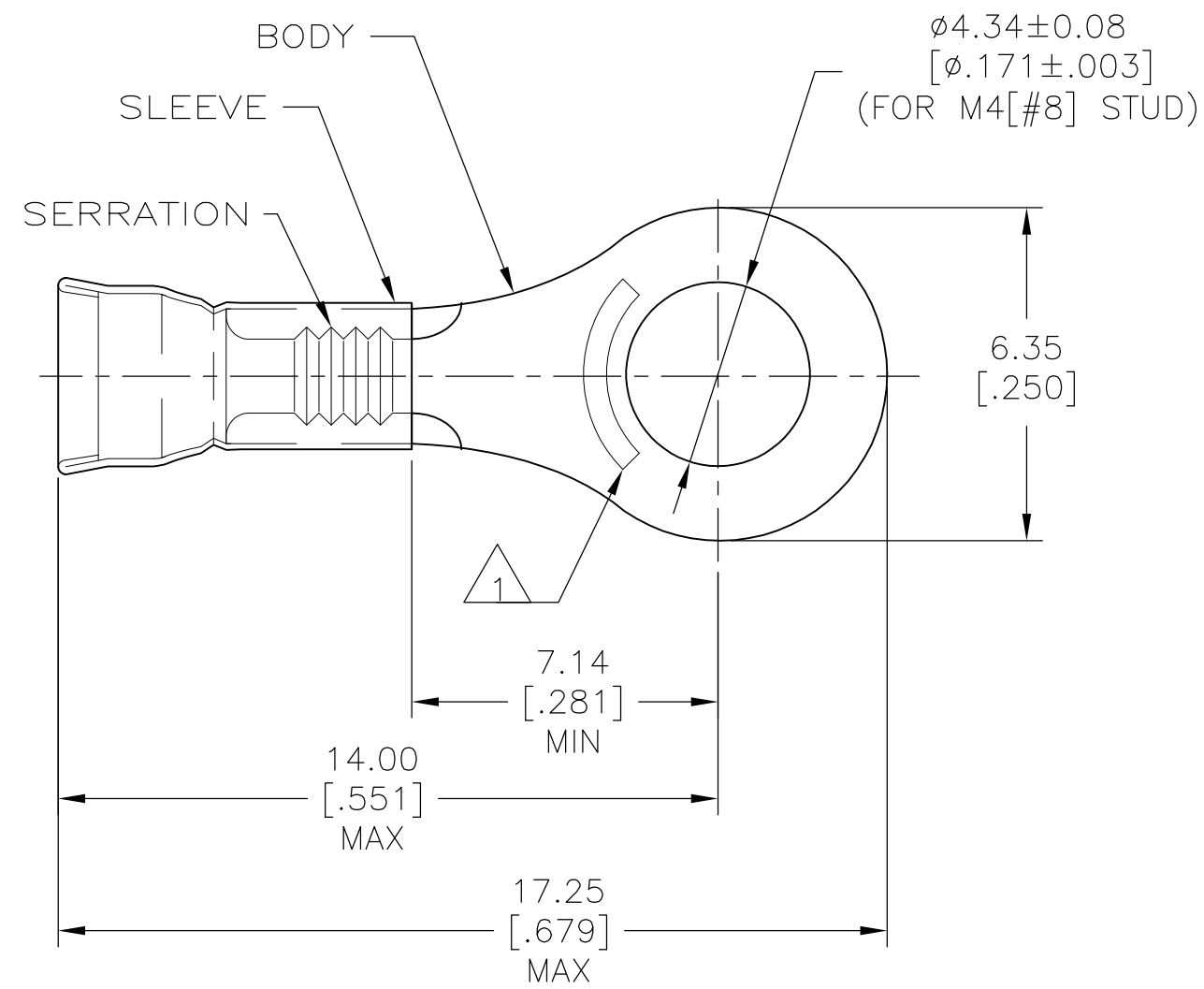

- 1 STAMP AMP LOCATE APPROX AS SHOWN.
- 2 WIRE INSUL DIA, 1.27-2.08 [.050-.082].
- 3 TONGUE MATL THK, 0.46±0.05 [.018±.002].
- 4 GOLD PLATE PER MIL-G45204 OVER NICKEL PLATE PER QQ-N-290.
- 5 PREPRODUCTION - FASR REQUIRED.
- 6 TIN PLATE PER ASTM B545.

QTY	PACKAGE TYPE	FINISH	PART NO
1000	LOOSE PIECE	4 5	2-32862-2
5000	ON TAPE, REEL	6	2-32862-1
1000	LOOSE PIECE	6	32862

AMP INCORPORATED
 CUSTOMER SERVICE SYSTEMS

FOR ADDITIONAL PRODUCT INFORMATION OR COPIES OF DRAWINGS AND TECHNICAL DOCUMENTS	PRODUCT INFORMATION CENTER 1-800-522-6752	RECOMMENDED OPERATING TEMPERATURE: -
FOR APPLICATION TOOLING INFORMATION	TOOLING ASSISTANCE CENTER 1-800-722-1111	VOLTAGE RATING: -
FOR ORDER ENTRY	1-800-526-5142	CIRCULAR MIL AREA: 0.10mm ² -0.41mm ² [202-810] STRANDED WIRE

THIS DRAWING IS A CONTROLLED DOCUMENT.

DIMENSIONS: mm [INCHES]	TOLERANCES UNLESS OTHERWISE SPECIFIED:
	0 PLC ± -
	1 PLC ± -
	2 PLC ± 0.20 [.008]
	3 PLC ± -
	4 PLC ± -
	ANGLES ± -
MATERIAL BODY, CU, SLV, CU PER ASTM B152	FINISH SEE TABLE

DWN L OLMEDA 23JAN95	TE Connectivity NAME TERMINAL, RING, DIAMOND GRIP, WIRE SIZE: 26-22 AWG				
CHK M ELLIS 23JAN95					
APVD S BORTNER 23JAN95					
PRODUCT SPEC					
APPLICATION SPEC	SIZE A3	CAGE CODE 00779	DRAWING NO G-32862	RESTRICTED TO -	
WEIGHT -	CUSTOMER DRAWING		SCALE 6:1	SHEET 1 OF 1	REV D1