

PART NUMBER	REV	FIRST USED
1385032-1	A	122500-1

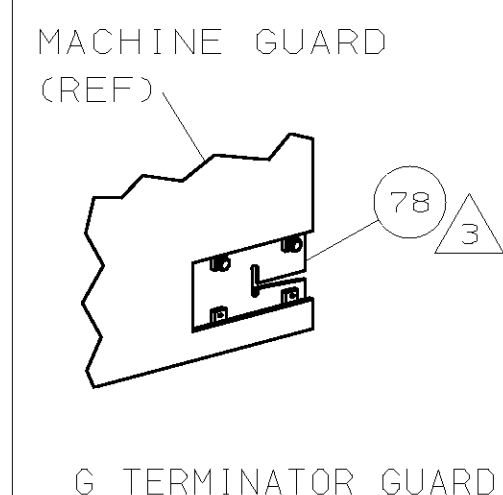

TERMINAL NAME: RECEPTAL, FASTON, ADAPTER, .250 SERIES			
PAD LTR	CRIMP HEIGHT	WIRE SIZE	
A	.2930 PIN	-	
B	NOT	USED	
C	NOT	USED	
D	NOT	USED	
CRIMP	SIZE	TYPE	RANGE
WIRE	-	-	-
INSUL	-	-	-

-1	LEADMAKER & BENCH MODEL G	MECH POST FEED
----	---------------------------	----------------

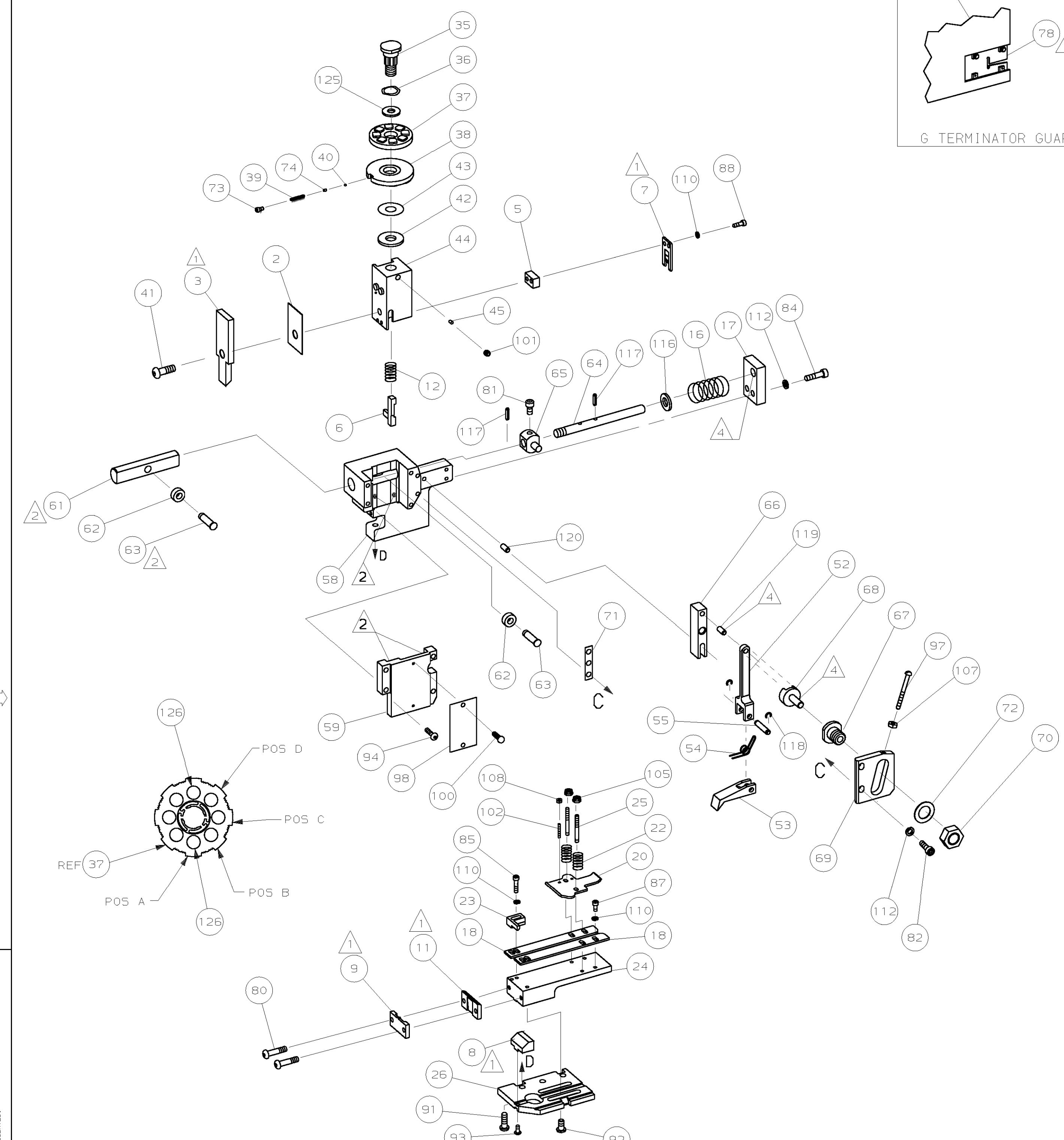

QTY	REF	U/M	TERM APPL SPEC	FEED	APPL INSTRUCTION	SET UP GAGE	LAYOUT	ITEM NO
			NONE	.760	408-8039	458638-1	L2342	129
								128
								127
2	-	C	8-354778-7		PIN, WIRE DISC (.2930)A			126
1	-	A	986950-1		WASHER, FLAT PRECISION			125
1	-	A	217238-1		GENERAL INSTRUCTION PACKAGE			124
1	-	-	4088039		EF APPL INST 408-8039			123
								122
								121
REF	-	A	1-21030-7		PIN, DOWEL (Ø.187x1.50)H56			120
REF	-	A	1-21030-1		PIN, DOWEL (Ø.187x.50)LEVER			119
REF	-	A	21045-3		RING, RET "C" (Ø.187)FD PIN			118
REF	-	A	5-21028-1		PIN, STD SPRING (Ø.12)FD ADJ ROD			117
REF	-	A	21899-4		WASHER, FLAT (Ø5/16) SCR ADJ			116
								115
								114
								113
REF	-	A	21024-5		WASHER, LOCK (NO.10)FD ROD GDE			112
								111
7	-	A	21024-4		WASHER, LOCK (NO.8)SHEAR BL			110
								109
2	-	A	21018-4		NUT, HEX (4-40)DRAG			108
REF	-	A	21018-5		NUT, HEX (6-32)FD ADJ PL			107
								106
2	-	A	21022-2		NUT, HEX SL (8-32)DRAG STUD			105
								104
								103
2	-	A	2-21006-6		SCR, SKT SET (4-40x.62)DRAG			102
1	-	A	21009-2		SCR, SKT SET (1/4-20x.25)RAM			101
2	-	A	21017-2		SCR, DRIVE (#2x.19) ID PLATE			100
1	-	A	1-21002-7		SCR, BHC (6-32x.38) CAM			99
1	-	B	461264-1		PLATE, IDENTIFICATION			98
REF	-	A	6-23715-5		SCR, PAN HD (6-32x1.50)FEED ADJ			97
								96
								95
REF	-	A	2-21002-9		SCR, BHC (10-32x.75)H56 CAP			94
1	-	A	22733-8		SCR, BHC (8-32x.38 LW) ANVIL			93
4	-	A	3-21002-3		SCR, BHC (1/4-20x.50)ST 6D PL			92
REF	-	A	2-22733-8		SCR, BHC (1/4-20x.62)BASE PL			91
								90
								89
5	-	A	2-21000-6		SCR, SHC (8-32x.38)SLUG BLADE			88
1	-	B	318848-1		AIR BLAST ASSY			87
								86
2	-	A	2-21000-7		SCR, SHC (8-32x.50)R STP GUIDE			85
REF	-	A	3-21000-7		SCR, SHC (10-32x.75)FEED ROD GDE			84
								83
REF	-	A	3-21000-6		SCR, SHC (10-32x.62)FEED ADJ PL			82
REF	-	A	3-21000-4		SCR, SHC (10-32x.38)PIVOT BLOCK			81
2	-	A	3-21002-0		SCR, BHC (10-32x.88)SHEAR PL			80
								79
REF	-	A	679532-1		INSERT, GUARD			78
								77
								76
								75
1	-	A	690603-1		SPRING, ASSIST			74
1	-	A	23030-1		SCR, SKT CAP (6-32x.25)CP DSC			73
REF	-	A	458109-1		WASHER, FLAT (SPECIAL)			72
REF	-	A	690517-1		SPACER			71

REF								
REF	-	A	22594-8		NUT, HEX			70
REF	-	B	240628-1		PLATE, ADJ			69
REF	-	B	240626-1		SHAFT, PIVOT			68
REF	-	B	240633-1		BUSHING			67
REF	-	A	455680-1		LEVER, INTERMEDIATE			66
REF	-	B	240629-1		BLOCK, PIVOT			65
REF	-	A	240632-2		SCR, ADJ			64
REF	-	B	240659-3		PIN, CAM ROLLER			63
REF	-	B	240658-1		CAM, ROLLER			62
REF	-	B	454398-1		ROD, FEED			61
								60
REF	-	C	454220-1		CAP, RAM			59
REF	-	D	453736-1		HOUSING			58
								57
								56
REF	-	B	240624-1		PIN, FEED FINGER			55
REF	-	B	691499-1		SPRING, FEED FINGER			54
REF	-	B	240635-1		FINGER, FEED			53
REF	-	B	240634-1		LEVER, TERMINAL			52
								51
								50
								49
								48
1	-	B	690501-4		CAM, POST-FEED 1 5/8 ST			47
								46
1	-	A	690191-1		PLUG, NYLON			45
1	-	C	455674-1		RAM			44
1	-	A	690125-1		WASHER, LAMINATED			43
1	-	A	690124-1		WASHER, RAM			42
1	-	A	7-21002-9		BOLT, CRIMPER (5/16-24x1.00)			41
1	-	A	23241-6		BALL, STEEL			40
1	-	A	690170-1		SPRING, COMPRESSION			39
1	-	C	690142-1		DISC, INSULATION			38
1	-	D	354777-1		WIRE DISC, PLASTIC			37
1	-	A	22480-5		WASHER, SPRING			36
1	-	B	690212-1		POST, RAM			35
								34
								33
1	-	D	458980-1		APPLICATOR, BASIC (SUB ASSY)			32
								31
								30
								29
								28
								27
REF	-	C	455676-1		PLATE, BASE			26
2	-	A	22354-8		DRAG, STUD			25
1	-	B	455678-1		PLATE, STRIP GUIDE			24
1	-	C	240825-9		PLATE, STRIP HOLD DOWN			23
2	-	A	4-22281-1		SPRING, DRAG			22
								21
1	-	A	454177-1		DRAG, STOCK			20
								19
2	-	C	454204-1		GUIDE, STRIP (FRONT)			18
REF	-	A	454178-1		GUIDE, FEED ROD			17
REF	-	A	4-22284-9		SPRING, FEED RETURN			16
								15
								14
								13
1	-	A	23846-1		SPRING, HOLD DOWN			12
1	-	B	240644-1		PLATE, REAR SHEAR			11
								10
1	-	B	690482-6		PLATE, FRONT SHEAR			9
1	-	D	1338474-1		ANVIL			8
1	-	B	690474-6		BLADE, SLUG			7
1	-	D	2-455892-1		HOLD DOWN, TERMINAL			6
1	-	C	240641-7		SPACER, SLUG BLADE			5
								4
1	-	C	1338473-2		CRIMPER, INSULATION			3
1	-	B	1-455888-9		SPACER, CRIMPER			2
								1

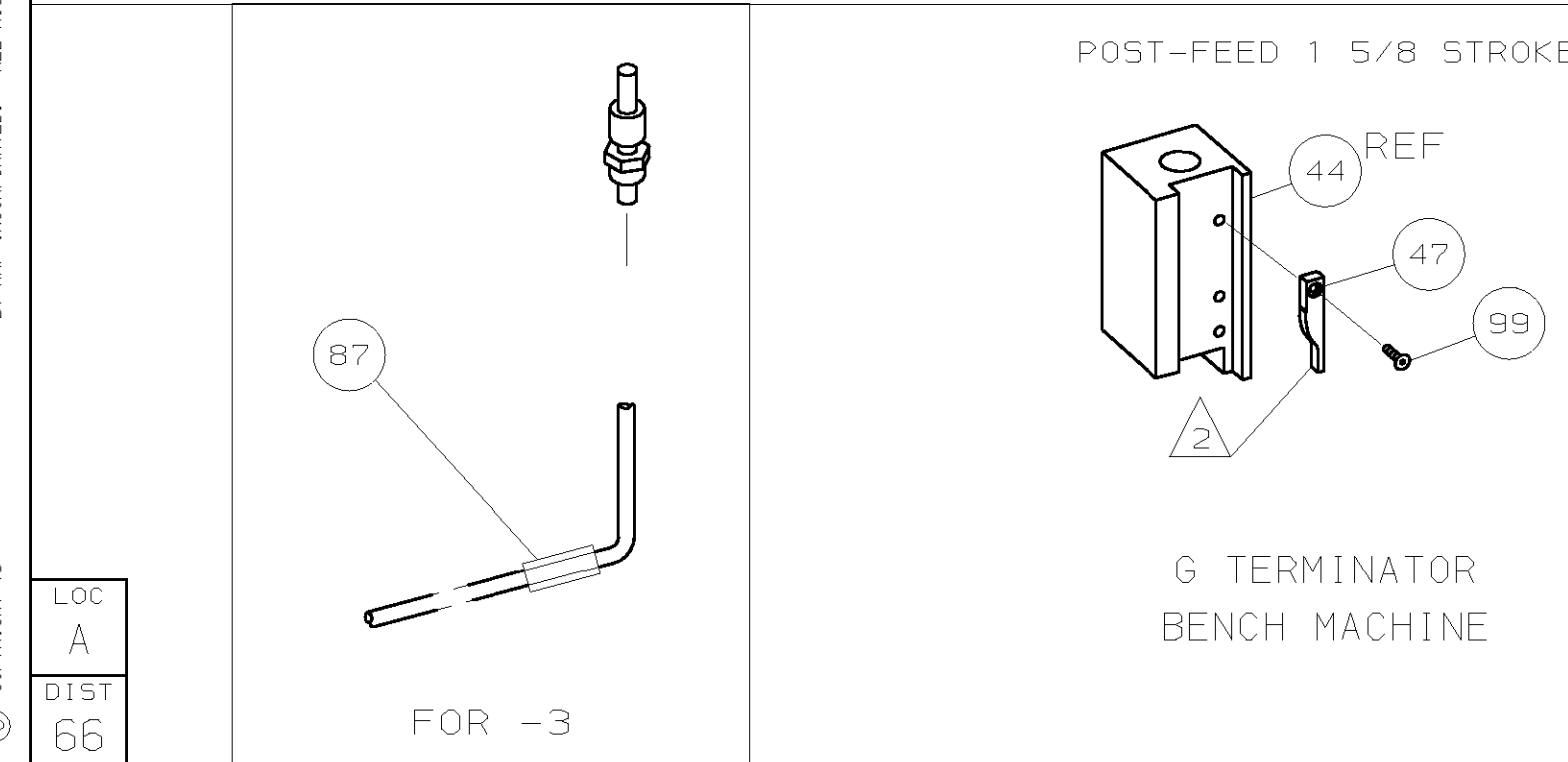

- 1 RECOMMENDED SPARE PARTS.
- 2 GREASE LIGHTLY.
- 3 GUARD MUST BE IN PLACE WHEN OPERATING APPLICATOR IN A BENCH MACHINE.
- 4 LUBRICATE DAILY USING NO. 20 MACHINE OIL.
- 5. ITEMS WITH QTY OF REF SPECIFIED (EXCEPT ITEMS 78 AND 79) ARE USED ON ITEM 32.
- 6 ITEM 78 USED WITH 6 TERMINATOR ONLY.

QTY	REF	U/M	DWG SIZE	PART NO	DESCRIPTION	ITEM NO

QTY	REF	U/M	DWG SIZE	PART NO	DESCRIPTION	ITEM NO