

## Automotive-grade 5-line transient voltage suppressor (TVS) for ESD protection

Datasheet - production data

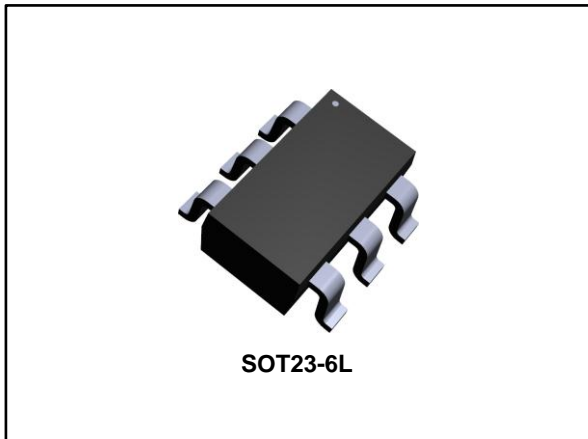

### Applications

This device is used to protect equipment in which ESD and EOS transient overvoltage may damage electronic circuits.

### Description

This device is a monolithic voltage suppressor designed to protect components connected to data and transmission lines against ESD.

It clamps the voltage just above the logic level supply for positive transients, and to a diode drop below ground for negative transients.

### Features

- AEC-Q101 qualified
- 5 unidirectional TVS functions
- UL 94 V-0
- J-STD-020 MSL level 1



### Benefits

- Suitable for high density boards

### Complies with the following standards

- ISO 10605 / IEC 61000-4-2: C = 150 pF, R = 330 Ω
  - 30 kV (air discharge)
  - 18 kV (contact discharge)
- ISO 10605: C = 330 pF, R = 330 Ω
  - 20 kV (air discharge)
  - 13 kV (contact discharge)
- ISO 7637-3
  - Pulse 3a:  $V_s = -150\text{ V}$
  - Pulse 3b:  $V_s = +100\text{ V}$

Figure 1: Pin configuration

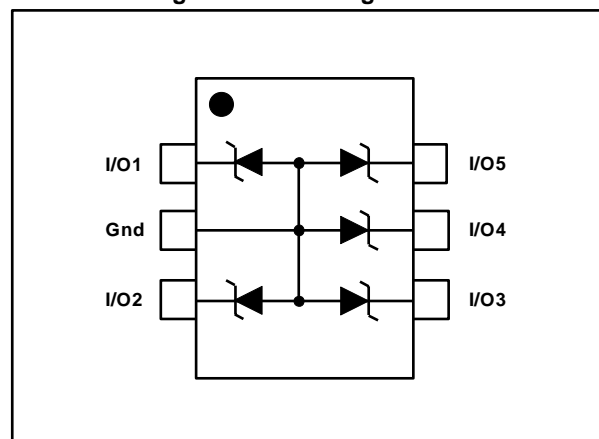

# 1 Characteristics

**Table 1: Absolute ratings (Tamb = 25 °C)**

Symbol	Parameter		Value	Unit
V <sub>pp</sub>	Peak pulse voltage	ISO 10605 / IEC 61000-4-2 (C = 150 pF, R = 330 Ω)	30	kV
		Contact discharge	18	
		Air discharge		
		ISO10605 (C = 330 pF, R = 330 Ω)	20	
		Contact discharge	13	
		Air discharge		
I <sub>pp</sub>	Peak pulse current	8/20µs	7	A
P <sub>pp</sub>	Peak pulse power		80	W
T <sub>stg</sub>	Storage temperature range		-65 to +150	°C
T <sub>j</sub>	Operating junction temperature range		-40 to +150	
T <sub>L</sub>	Maximum temperature for soldering during 10 s		260	

**Figure 2: Electrical characteristics (definitions)**

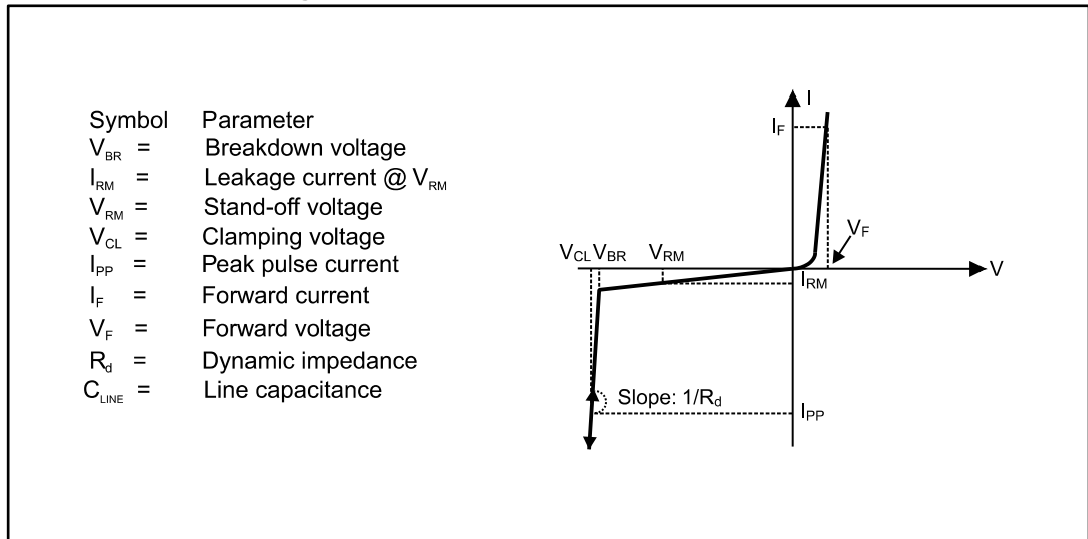

**Table 2: Electrical characteristics - values (Tamb = 25 °C)**

Order code	V <sub>BR</sub> at I <sub>R</sub>		I <sub>RM</sub> at V <sub>RM</sub>		V <sub>CL</sub> at I <sub>pp</sub> <sup>(1)</sup>		V <sub>F</sub> at I <sub>F</sub>		αT <sup>(2)</sup>	C <sub>line</sub>	
	Min.	Max.	Max.		Max.		Max.		Max.	Typ.	
	V	V	mA	µA	V	V	A	V	mA	10 <sup>-4</sup> /C	pF
ESDA6V1-5SC6Y	6.1	7.2	1	1	5.2	11.4	7	1.25	200	6	50

**Notes:**

<sup>(1)</sup>8/20 µs waveform

<sup>(2)</sup>V<sub>BR</sub> at T<sub>j</sub> = V<sub>BR</sub> at 25 °C x (1 + αT x (T<sub>j</sub> - 25))

Figure 3: Pulse definition for electrical characteristics

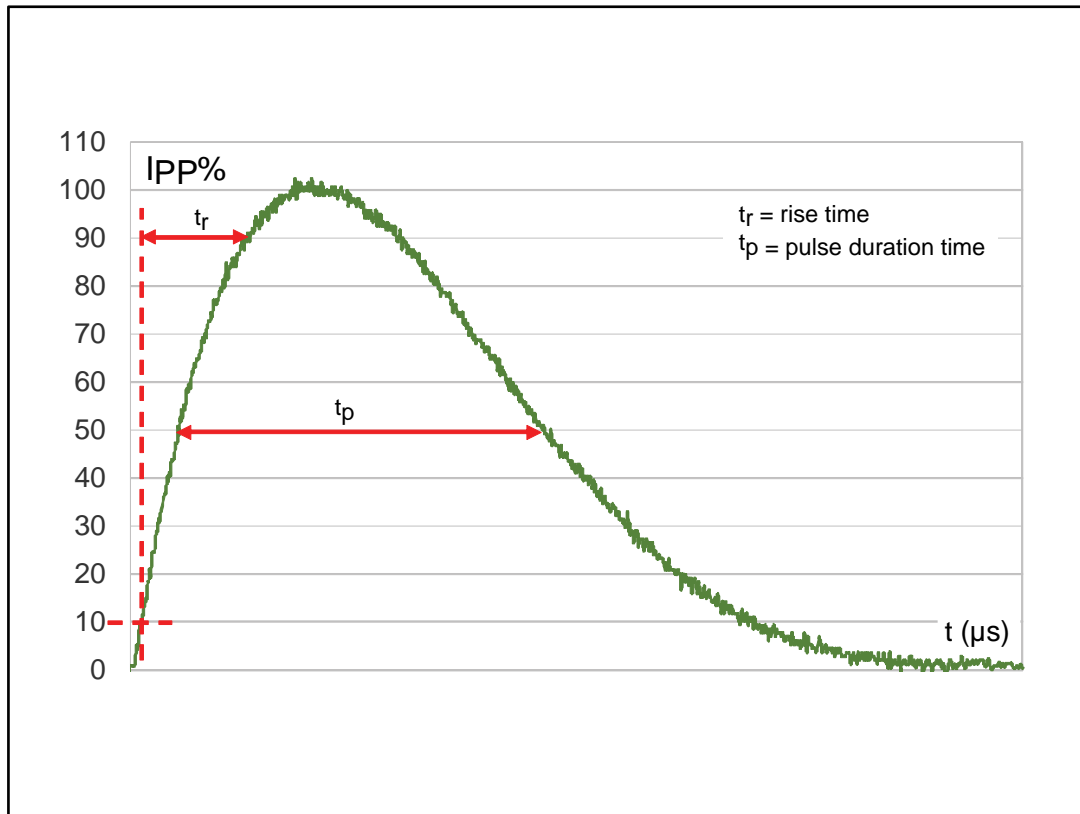

# 1.1 Characteristics (curves)

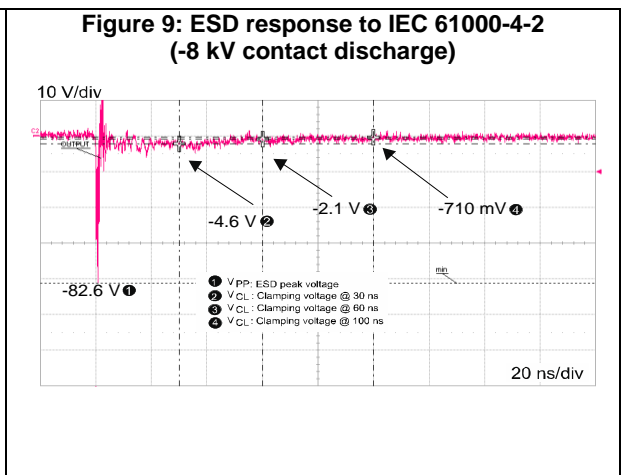
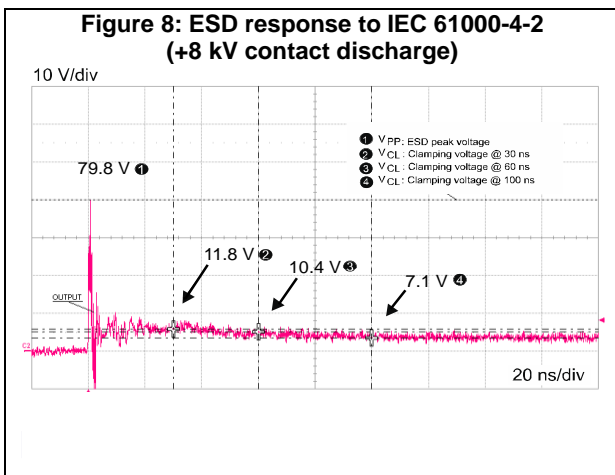
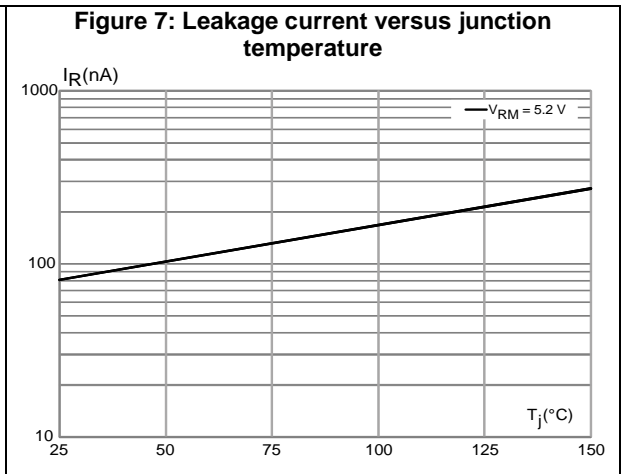
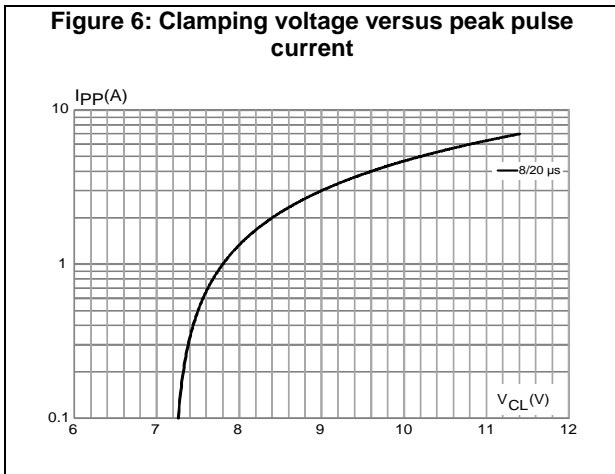
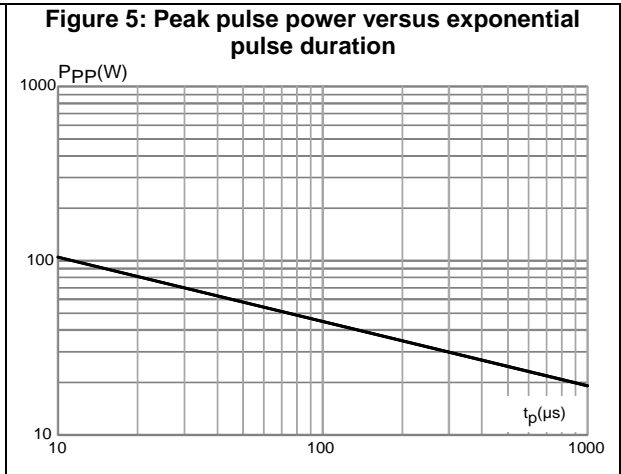
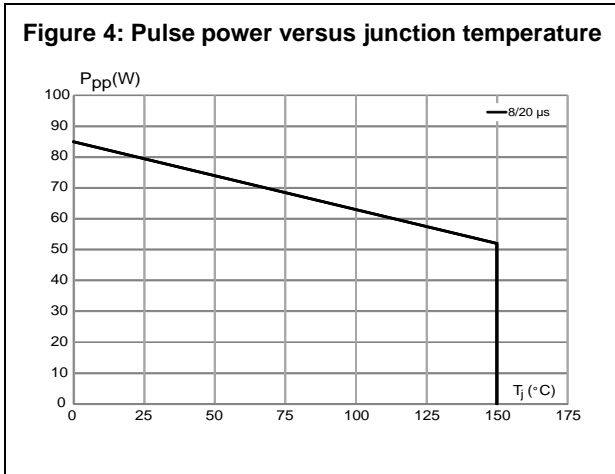

Figure 10: ISO7637-3 pulse 3a response ( $V_s = -150\text{ V}$ )

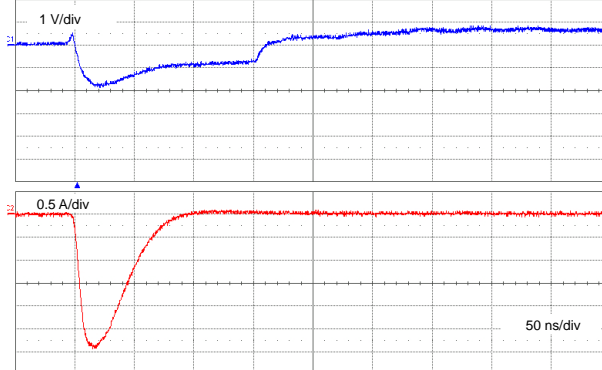
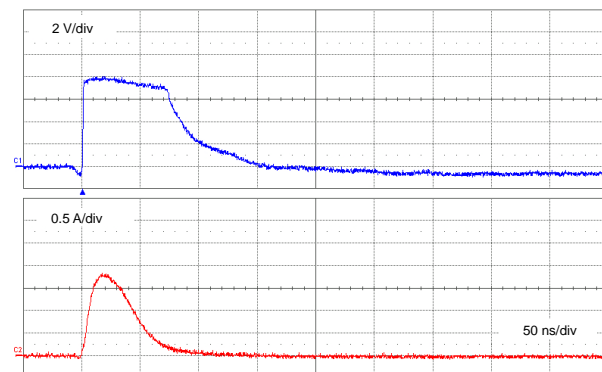

Figure 11: ISO7637-3 pulse 3b response ( $V_s = 100\text{ V}$ )



## 2 Application and design guidelines

Further information can be found in AN2689 titled: "Protection of automotive electronics from electrical hazards, guidelines for design and component selection".

### 3 Package information

In order to meet environmental requirements, ST offers these devices in different grades of ECOPACK® packages, depending on their level of environmental compliance. ECOPACK® specifications, grade definitions and product status are available at: [www.st.com](http://www.st.com). ECOPACK® is an ST trademark.

- Epoxy meets UL 94,V0
- Lead-free package

#### 3.1 SOT23-6L package information

Figure 12: SOT23-6L package outline

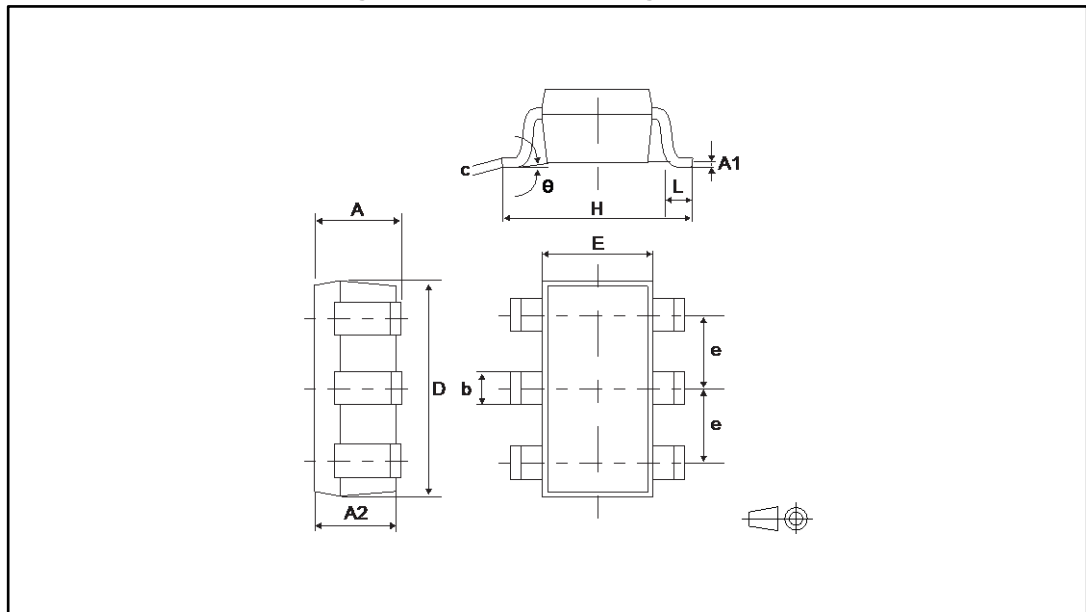

Table 3: SOT23-6L package mechanical data

Ref.	Dimensions					
	Millimeters			Inches		
	Min.	Typ.	Max.	Min.	Typ.	Max.
A	0.9		1.45	0.0354		0.0571
A1	0		0.15	0		0.0059
A2	0.9		1.3	0.0354		0.0512
b	0.30		0.5	0.0118		0.0197
c	0.09		0.2	0.0035		0.0079
D	2.8		3.05	0.1102		0.1201
E	1.5		1.75	0.0591		0.0689
e		0.95			0.0374	
H	2.6		3	0.1024		0.1181
L	0.3		0.6	0.0118		0.0236
θ	0		10	0		0.3937

Figure 13: Footprint recommendations, dimensions in mm (inches)

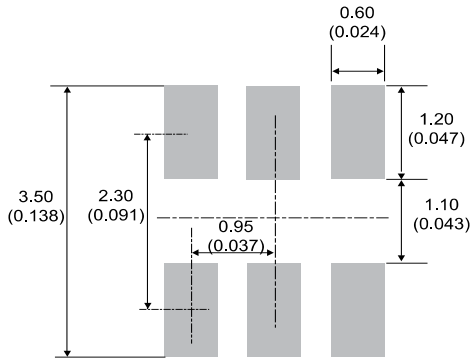

Figure 14: Marking layout (refer to ordering information table for marking)

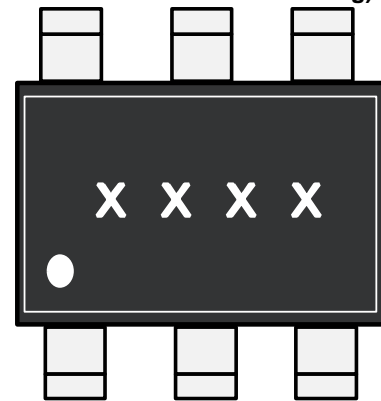
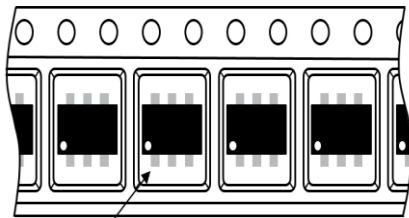

Figure 15: Package orientation in reel



Pin 1 located according to EIA-481

Note: Pocket dimensions are not on scale  
Pocket shape may vary depending on package

Figure 16: Tape and reel orientation

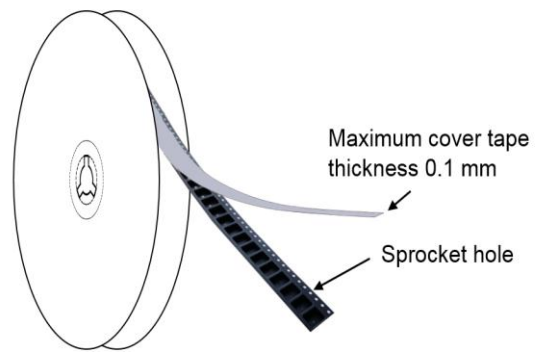

Figure 17: Reel dimensions (mm)

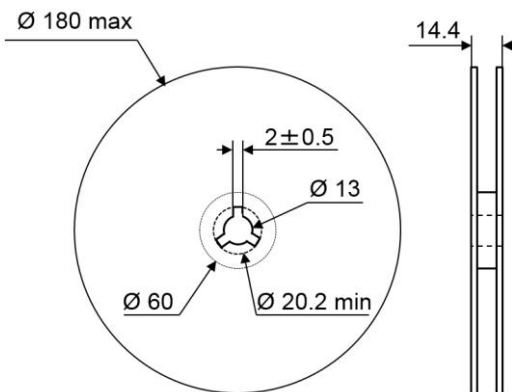

Figure 18: Inner box dimensions (mm)

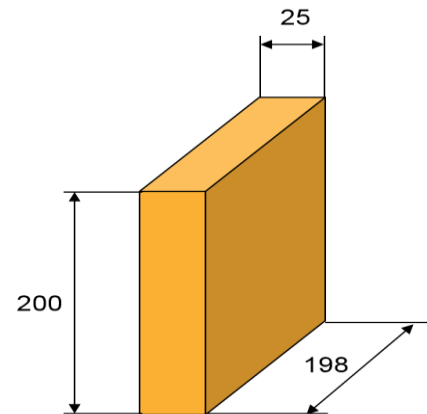



Figure 19: Tape and reel outline

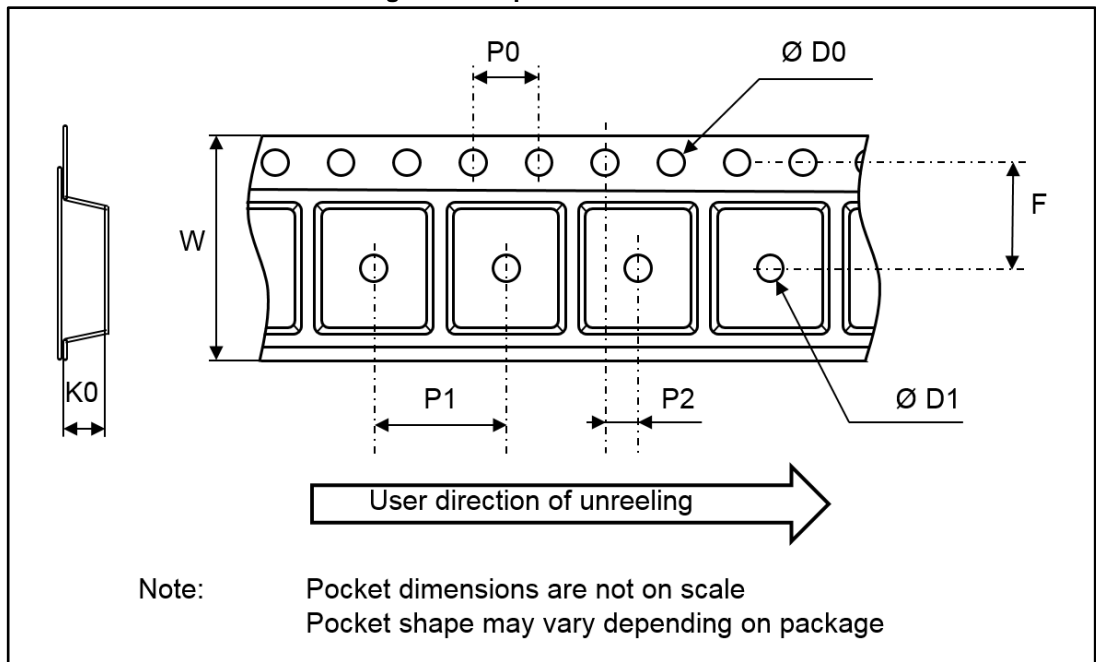

Table 4: Tape and reel mechanical data

Ref.	Dimensions		
	Millimeters		
	Min.	Typ.	Max.
P1	3.9	4	4.1
P0	3.9	4	4.1
D0	1.45	1.5	1.6
D1	1		
F	3.45	3.5	3.55
K0	1.3	1.4	1.6
P2	1.95	2	2.05
W	7.9	8	8.3

## 4 Ordering information

Figure 20: Ordering information scheme

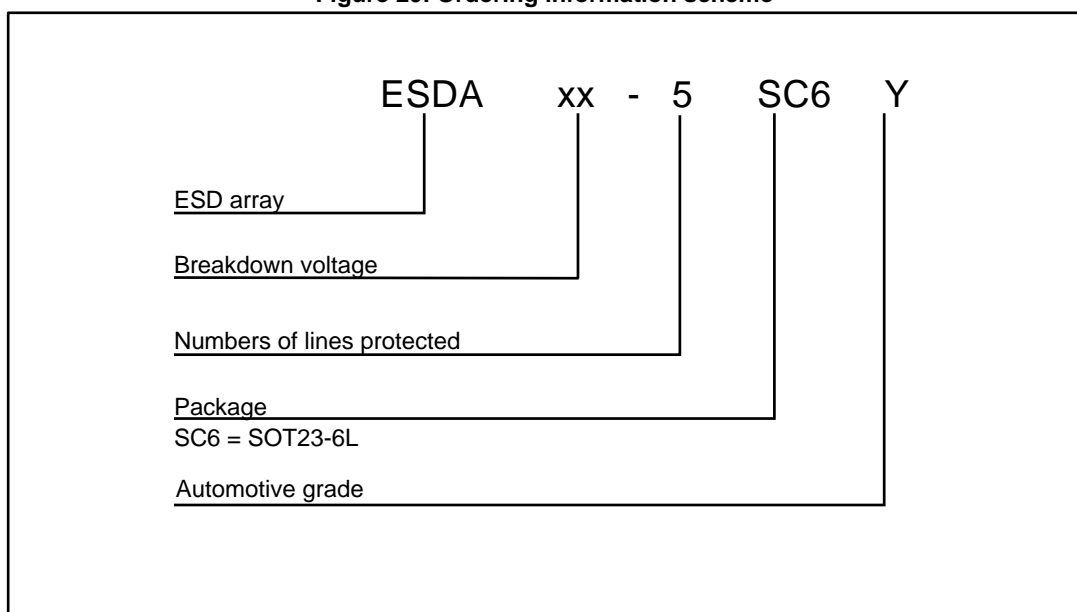

Table 5: Ordering information

Order code	Marking	Package	Weight	Base qty.	Delivery mode
ESDA6V1-5SC6Y	EC6Y	SOT23-6L	14 mg	3000	Tape and reel

## 5 Revision history

**Table 6: Document revision history**

Date	Revision	Changes
08-Nov-2016	1	Initial release.
15-Mar-2017	2	Updated title and description in cover page. Minor text changes to improve readability.
03-May-2017	3	Formatting improvement, no content changes.

**IMPORTANT NOTICE – PLEASE READ CAREFULLY**

STMicroelectronics NV and its subsidiaries ("ST") reserve the right to make changes, corrections, enhancements, modifications, and improvements to ST products and/or to this document at any time without notice. Purchasers should obtain the latest relevant information on ST products before placing orders. ST products are sold pursuant to ST's terms and conditions of sale in place at the time of order acknowledgement.

Purchasers are solely responsible for the choice, selection, and use of ST products and ST assumes no liability for application assistance or the design of Purchasers' products.

No license, express or implied, to any intellectual property right is granted by ST herein.

Resale of ST products with provisions different from the information set forth herein shall void any warranty granted by ST for such product.

ST and the ST logo are trademarks of ST. All other product or service names are the property of their respective owners.

Information in this document supersedes and replaces information previously supplied in any prior versions of this document.

© 2017 STMicroelectronics – All rights reserved