

10 9 8 7 6 5 4 3 2 1

F  
E  
D  
C  
B  
A

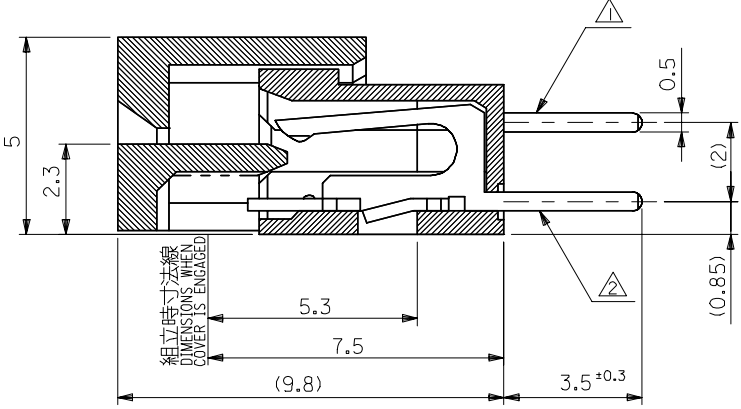
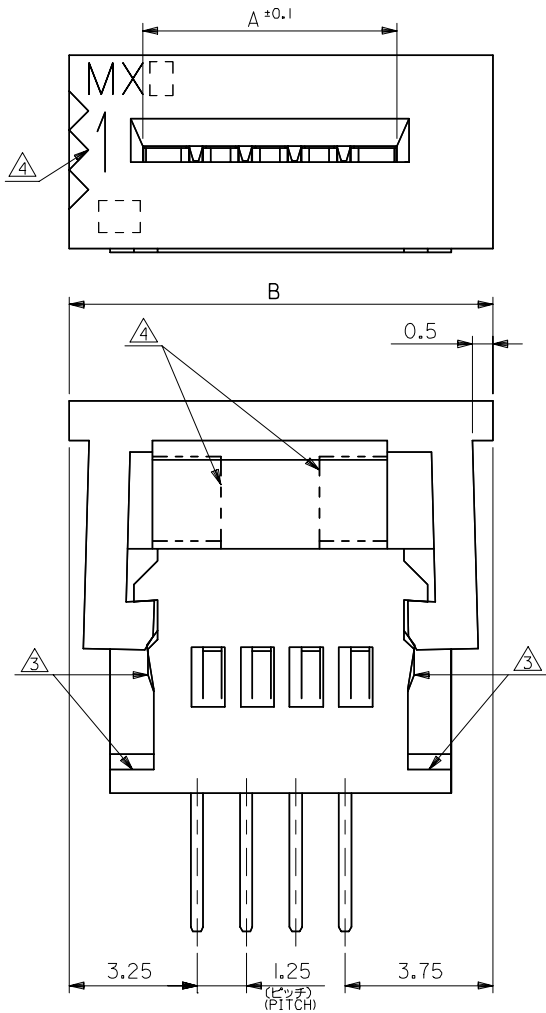

49.5	45.2	39-53-2355	5597-35CPB7F	35
48.25	43.95	↑ -2345	↑ -34CPB7F	34
47	42.7	↑ -2335	↑ -33CPB7F	33
45.75	41.45	↑ -2325	↑ -32CPB7F	32
44.5	40.2	↑ -2315	↑ -31CPB7F	31
43.25	38.95	↑ -2305	↑ -30CPB7F	30
42	37.7	↑ -2295	↑ -29CPB7F	29
40.75	36.45	↑ -2285	↑ -28CPB7F	28
39.5	35.2	↑ -2275	↑ -27CPB7F	27
38.25	33.95	↑ -2265	↑ -26CPB7F	26
37	32.7	↑ -2255	↑ -25CPB7F	25
35.75	31.45	↑ -2245	↑ -24CPB7F	24
34.5	30.2	↑ -2235	↑ -23CPB7F	23
33.25	28.95	↑ -2225	↑ -22CPB7F	22
32	27.7	↑ -2215	↑ -21CPB7F	21
30.75	26.45	↑ -2205	↑ -20CPB7F	20
29.5	25.2	↑ -2195	↑ -19CPB7F	19
28.25	23.95	↑ -2185	↑ -18CPB7F	18
27	22.7	↑ -2175	↑ -17CPB7F	17
25.75	21.45	↑ -2165	↑ -16CPB7F	16
24.5	20.2	↑ -2155	↑ -15CPB7F	15
23.25	18.95	↑ -2145	↑ -14CPB7F	14
22	17.7	↑ -2135	↑ -13CPB7F	13
20.75	16.45	↑ -2125	↑ -12CPB7F	12
19.5	15.2	↑ -2115	↑ -11CPB7F	11
18.25	13.95	↑ -2105	↑ -10CPB7F	10
17	12.7	↑ -2095	↑ -09CPB7F	9
15.75	11.45	↑ -2085	↑ -08CPB7F	8
14.5	10.2	↑ -2075	↑ -07CPB7F	7
13.25	8.95	↑ -2065	↑ -06CPB7F	6
12	7.7	↑ -2055	↑ -05CPB7F	5
10.75	6.45	↓ -2045	↓ -04CPB7F	4
9.5	5.2	↓ 39-53-2035	↓ 5597-03CPB7F	3

MODEL NO. 5597-NCPB7F B A EDP.NO. ENG. NO. 極数

REVISED EC NO: J2005-4741 DRAWN: SUZUKI CHKD: KTOJO APPR: NUKITA	GENERAL TOLERANCES (UNLESS SPECIFIED)		DIMENSION STYLE MM ONLY		SCALE ---		DESIGN UNITS METRIC		THIRD ANGLE PROJECTION	
	10 UNDER	± 0.2	DRAWN BY YWADA		DATE 04/02/19		TITLE 1.25 FPC CONN ASSY ZIF			
	10 OVER 30 UNDER	± 0.25	CHECKED BY MSASAO		DATE 04/02/19		-LEAD FREE-			
	30 OVER	± 0.3	APPROVED BY MSASAO		DATE 04/02/19		MOLEX INCORPORATED			
	ANGULAR	± 3 °	MATERIAL NO. SEE CHART		DOCUMENT NO. SD-5597-007		SHEET NO. 1 OF 2			

THIS DRAWING CONTAINS INFORMATION THAT IS PROPRIETARY TO MOLEX INCORPORATED AND SHOULD NOT BE USED WITHOUT WRITTEN PERMISSION

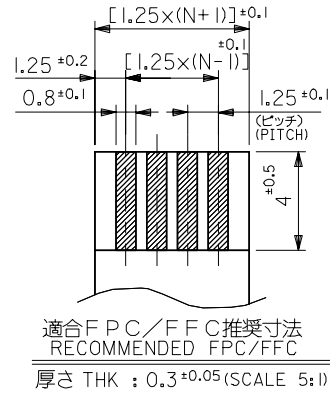
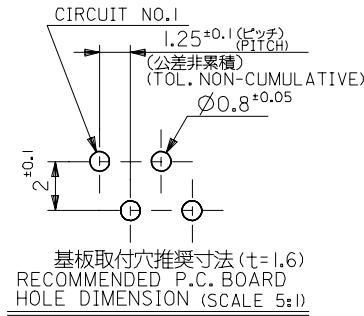

FPCについて:

打抜き方向は導体側から補強板側を推奨いたします。  
補強フィルム材質はポリイミドを推奨致します。  
接着剤は熱硬化接着剤を推奨致します。

ABOUT FPC:

RECOMMENDED PUNCHER DIRECTION :  
FROM CONDUCTOR SIDE TO STIFFENER BOARD SIDE.  
RECOMMENDED MATERIAL:  
STIFFENER FILM : POLYIMIDE  
BONDING AGENT : THERMOSETTING BONDING AGENT

注記 NOTES

- ① MX J側を基準に奇数番目の極におけるソルダーテール。  
SOLDER TAIL OF ODD CKTS, MXJ MARK AS BASIC.
- ② MX J側を基準に偶数番目の極におけるソルダーテール。  
SOLDER TAIL OF EVEN CKTS, MXJ MARK AS BASIC.
- ③ 3極~10極に適用。APPLY FOR 3-10 CKTS.
- ④ 3極~19極に適用。APPLY FOR 3-19 CKTS.
- 5. ( ) 内寸法は、参考値。  
( ) DIMENSION IS FOR REFERENCE.
- 6. ソルダーテールは、先端が取付推奨穴にガイドされること。  
SOLDER TAILS MAY BE CHECKED BY INSERTION  
FOR RECOMMENDED PCB BOARD HOLES.

7. 使用材料 MATERIAL

ハウジング、アクチュエーター: PBTP, UL94V-0  
HOUSING, ACTUATOR: PBTP, UL94V-0  
ターミナル: リン青銅 (t=0.3)  
PHOSPHOR BRONZE (t=0.3)  
錫ピスマスメッキ 1.0µm MIN.  
TIN-BISMUTH 1.0 MICROMETER MIN.  
ニッケル下地 1.0µm MIN.  
NICKEL 1.0 MICROMETER MIN.

8. 本製品は5597-NCPBの鉛フリー品である。  
THIS PRODUCT IS LEAD FREE OF 5597-NCPB.

REVISED EC NO: J2005-1741 DRAWN: SUZUKI CHKD: KATO APP: NUKITA REV: A	GENERAL TOLERANCES (UNLESS SPECIFIED)		DIMENSION STYLE MM ONLY		SCALE ---	DESIGN UNITS METRIC	THIRD ANGLE PROJECTION	
	10 UNDER	±0.2	DRAWN BY YWADA	DATE 04/02/19	TITLE 1.25 FPC CONN ASSY ZIF			
	10 OVER 30 UNDER	±0.25	CHECKED BY MSASAO	DATE 04/02/19	-LEAD FREE-			
	30 OVER	±0.3	APPROVED BY MSASAO	DATE 04/02/19	MOLEX INCORPORATED			
	ANGULAR ±3 °		MATERIAL NO.	DOCUMENT NO.	SHEET NO.			
DRAFT WHERE APPLICABLE MUST REMAIN WITHIN DIMENSIONS		SEE CHART		SD-5597-007		2 OF 2		
SIZE A3 THIS DRAWING CONTAINS INFORMATION THAT IS PROPRIETARY TO MOLEX INCORPORATED AND SHOULD NOT BE USED WITHOUT WRITTEN PERMISSION								