

# Demonstration Board EPC9102

## Quick Start Guide

*1/8<sup>th</sup> Brick Converter featuring EPC2001*



## DESCRIPTION

[www.epc-co.com](http://www.epc-co.com)

The EPC9102 demonstration board is a 12 V output, 375 kHz phase shifted full bridge (PSFB) eighth brick converter with 17 A maximum output current and 36 V to 60 V input voltage range. The demonstration board features the EPC2001 enhancement mode (*eGaN*<sup>®</sup>) field effect transistors (FETs), as well as the first *eGaN* FET specific integrated circuit driver – the National LM5113 from Texas Instruments. The EPC9102 board is intended to showcase the performance that can be achieved using the *eGaN* FETs and *eGaN* driver together.

The EPC9102 demonstration board is oversized to allow connections for bench evaluation.

There are also various probe points to facilitate simple waveform measurement and efficiency calculation. A complete block diagram of the circuit is given in Figure 1. For more information on the EPC2001 *eGaN* FETs or LM5113 driver, please refer to the datasheet available from EPC at [www.epc-co.com](http://www.epc-co.com) and [www.ti.com](http://www.ti.com). These datasheets, as well that of the LM5030 controller should be read in conjunction with this quick start guide.

**Table 1: Performance Summary (TA = 25 °C)**

SYMBOL	PARAMETER	CONDITIONS	MIN	TYP	MAX	UNITS
V <sub>IN</sub>	Bus Input Voltage Range		36	48	60	V
V <sub>OUT</sub>	Switch Node Output Voltage			12		V
I <sub>OUT</sub>	Switch Node Output Current	T <sub>a</sub> = 25 °C, no forced air cooling <sup>†</sup> T <sub>a</sub> = 25 °C, ~200 LFM T <sub>a</sub> = 25 °C, ~400 LFM			8* 15* 17*	A A A
f <sub>SW</sub>	Switching frequency			375		kHz
	Output ripple frequency			750		kHz
	Peak Efficiency	36 V <sub>IN</sub> 10 A I <sub>OUT</sub>		94.8		%
	Full Load Efficiency	48 V <sub>IN</sub> 17 A I <sub>OUT</sub>		94		%
	Full Load Efficiency	60 V <sub>IN</sub> 17 A I <sub>OUT</sub>		93.5		%
	Full Load Efficiency	36 V <sub>IN</sub> 17 A I <sub>OUT</sub>		94		%

\* Maximum limited by thermal considerations

† Board placed vertical on long edge to aid convection – Do NOT operate horizontally without forced air cooling

# Quick Start Procedure

Demonstration board EPC9102 is easy to set up to evaluate the performance of the EPC2001 *eGaN* FETs and LM5113 driver. Refer to Figure 2 for proper connect and measurement setup and follow the procedure below:

1. With power off, connect the input power supply bus between VIN and INPUT RET banana jacks as shown.
2. Add input and output voltage measurements to the Kelvin connections provided as shown.
3. With power off, connect the active (constant current) load as desired between VOUT and OUT RET banana jacks as shown.
4. Turn on the supply voltage to the required value. (do not exceed the absolute maximum voltage of 60 V on VIN).
5. Measure the output voltage to make sure the board is fully functional and operating no-load.
6. Turn on active load to the desired load current while staying below the maximum current (This will depend on the cooling provided. If no forced air cooling, then keep the load current below 8 A)
7. Once operational, adjust the bus voltage and load current within the allowed operating range and observe the output switching behavior, efficiency and other parameters.
8. For shutdown, please follow steps in reverse.

NOTE. When measuring the high frequency content switch node voltage, care must be taken to avoid long ground leads. Measure these by placing the oscilloscope probe tip through the large vias provided and grounding the probe directly across the return vias provided. See Figure 3 for proper scope probe technique. Scope jacks can be soldered onto the board at these locations as desired. **Please note that primary side switch node scope jacks are referenced to the TOP of the sense resistor and not GND.** When measuring multiple signals ensure that they are always referenced to the same 'ground' potential to avoid potential circuit failure.

## CIRCUIT PERFORMANCE

The EPC9102 demonstration circuit was designed to showcase the size and performance that can readily be achieved at 375 kHz operation using *eGaN* FETs rather than to optimize the design for maximum output power. The operating frequency is roughly 50% - 100% higher than similar commercial units.

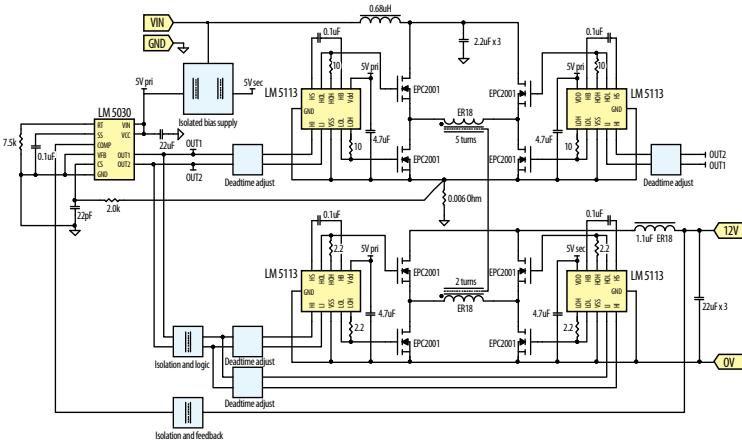

Figure 1: Block Diagram of EPC9102 Demonstration Board

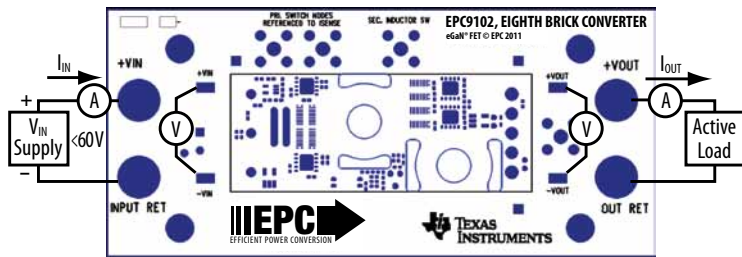

Figure 2: Proper Connection and Measurement Setup

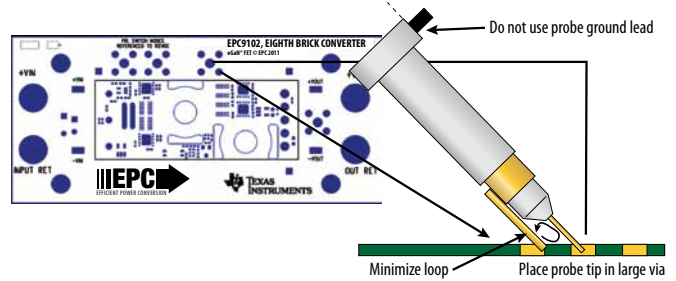

Figure 3: Proper Measurement of Switch Nodes or Output Voltage

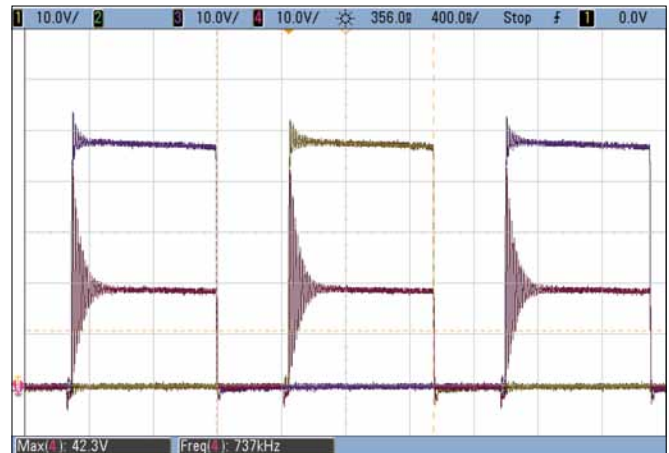

Figure 4: Typical waveforms taken at 48 V<sub>IN</sub> to 12 V<sub>OUT</sub>/15 A<sub>OUT</sub>  
 CH1: Primary side switch node A voltage – CH3: Primary side switch node B voltage –  
 CH4: Secondary side bridge voltage

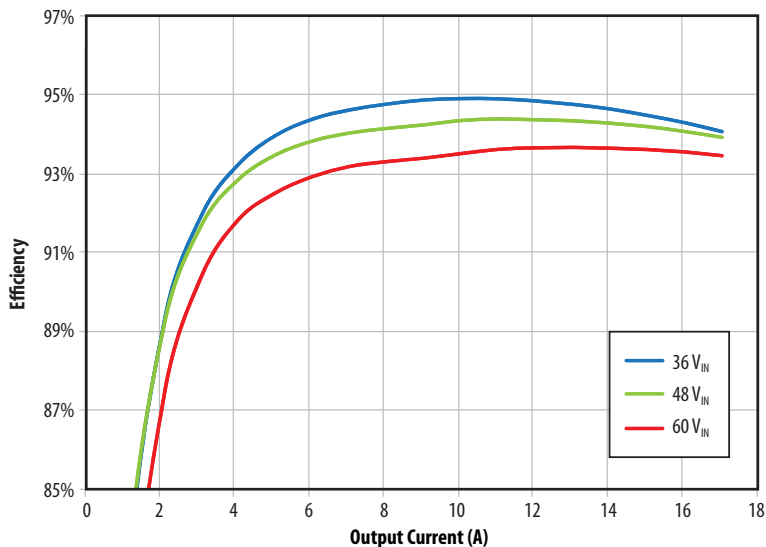

Figure 5: Typical efficiency curves

## THERMAL CONSIDERATIONS

The EPC9102 demonstration board thermal images for steady state full load operation are shown in Figure 6. The EPC9102 is intended for bench evaluation with low ambient temperature and forced air cooling. Operation without forced air cooling is possible for limited power operation and will quickly become thermally limited. Care must be taken to not exceed the absolute maximum junction temperature of 125 °C and stay within the constraints of the other components within the circuit.

NOTE. The EPC9102 demonstration board does not have any input overvoltage protection on board. Over-current is set to ~20 A, while primary side over temperature protection is set to ~90 °C. Care must be taken to avoid failure due to over temperature.

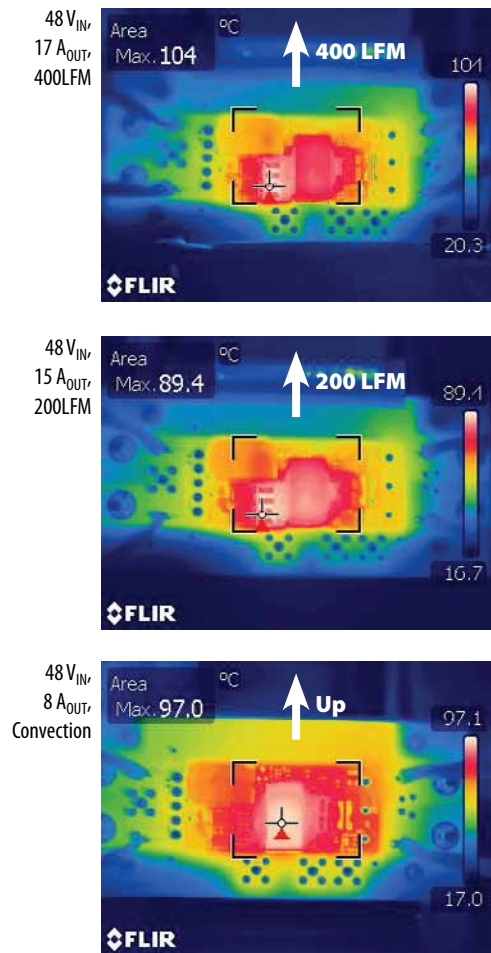

Figure 6: Thermal images of EPC9102 under different cooling conditions

**Table 2 : Bill of Material**

Item	Qty	Reference	Part Description	Manufacturer / Part #
1	6	C1, C2, C5, C18, C19, C31	Capacitor, 22uF, 16V, X5R, 10%	C2012X5R1C226K
2	1	C10	Capacitor, 0.22uF, 16V, X7R, 10%	GRM155R71C224KA12D
3	9	C11, C12, C13, C14, C21, C22, C23, C26, C35	Capacitor, 0.1uF, 16V, X7R, 10%	GRM155R71C104KA88D
4	4	C15, C27, C28, C37	Capacitor, 2.2uF, 6.3V, X5R	C1005X5R0J225M
5	1	C24	Capacitor, 680pF, 25V, NPO, 5%	C1005C0G1E681J
6	1	C25	Capacitor, 1uF, 6.3V, X5R, 10%	GRM155R60J105KE19D
7	4	C29, C30, C38, C45	Capacitor, 27pF, 50V, NPO, 5%	GRM1555C1H270JZ01D
8	3	C3, C6, C9	Capacitor, 2.2uF, 100V, X7R, 10%	HMK325BJ225KN-T
9	3	C32, C33, C41	Capacitor, 39pF, 50V, NPO, 5%	GRM1555C1H390JZ01D
10	1	C34	Capacitor, 47pF, 50V, NPO, 5%	GRM1555C1H470JZ01D
11	1	C36	Capacitor, 0.1uF, 100V, X7R, 10%	GRM188R72A104KA35D
12	1	C4	Capacitor, 0.22uF, 25V, X5R, 10%	TMK107BJ224KA-T
13	1	C40	Capacitor, 3300pF, 2000V, X7R, 10%	202543W332KV4E
14	1	C43	Capacitor, 330pF, 25V, NPO, 10%	ECJ-0EB1E331K
15	2	C44, C46	Capacitor, 3.3uF, 16V, X5R, 10%	C1608X5R1C335K
16	5	C7, C8, C16, C17, C20	Capacitor, 22pF, 50V, NPO, 5%	GRM1555C1H220JZ01D
17	5	D1, D2, D3, D4, D9	Diode, 100V, 0.2A SCHOTTKY	BAT41KFILM
18	4	D8, D10, D11, D12	Diode, 40V, 0.03A, SCHOTTKY	CDBQR00340
19	4	J1, J4, J5, J6	Connector, banana jack	KEYSTONE, 575-4
20	4	J7, J8, J10, J11	Test point	KEYSTONE, 5015
21	1	L1	Inductor, 0.68uH, 5.5A	Vishay, IHLP1212BZERR68M11
22	1	L2	Inductor, 1.2uH	Ferrox cube, ER18/3/10-3F35-A120
23	8	Q4, Q8, Q9, Q16, Q19, Q21, Q27, Q29	eGaN FET	EPC, EPC2001
24	1	R1	Resistor, 0.006, 2W, 1%	RL7520WT-R006-J
25	1	R10	Resistor, 499k, 1/16W, 1%	MCR01MZPF4993
26	5	R11, R12, R13, R23, R34	Resistor, 4.99k, 1/16W, 1%	CRCW04024K99FKED
27	4	R14, R20, R27, R50	Resistor, 10.0k, 1/16W, 1%	MCR01MZPF1002
28	2	R15, R48	Resistor, 33.2k, 1/16W, 1%	CRCW040233K2FKED
29	6	R17, R18, R46, R47, R56, R57	Resistor, 1.00k, 1/16W, 1%	RC0402FR-071KL
30	1	R19	Resistor, 38.3k, 1/16W, 1%	ERJ-2RKF3832X
31	1	R2	NTC, 10k, 1%	ERT-J0EG103FA
32	1	R21	Resistor, 10.0, 1/10W, 1%	ERJ-3EKF10ROV
33	1	R25	Resistor, 200k, 1/16W, 1%	CRCW0402200KFKED
34	1	R26	Resistor, 56, 1/16W, 1%	RC0402FR-0756RL
35	2	R28, R30	Resistor, 681, 1/16W, 1%	ERJ-2RKF6810X
36	2	R29, R31	Resistor, 910, 1/16W, 1%	RC0402FR-07910RL
37	1	R3	Resistor, 49.9k, 1/10W, 1%	ERJ-3EKF4992V
38	4	R32, R33, R36, R49	Resistor, 1.18k, 1/16W, 1%	CRCW04021K18FKED
39	1	R37	Resistor, 100, 1/10W, 1%	ERJ-3EKF1003V
40	4	R39, R40, R41, R43	Resistor, 2.21, 1/16W, 1%	CRCW04022R21FKED
41	1	R4	Resistor, 2.49k, 1/16W, 1%	CRCW04022K49FKED
42	1	R42	Resistor, 100, 1/16W, 1%	MCR01MZPF1000
43	1	R45	Resistor, 15.0k, 1/16W, 1%	MCR01MZPF1502
44	7	R5, R6, R8, R16, R35, R38, R44	Resistor, 10, 1/16W, 1%	RMCF0402F10R0TR-ND
45	1	R55	Resistor, 4.02k, 1/16W, 1%	ERJ-2RKF4021X
46	1	R7	Resistor, 6.81k, 1/16W, 1%	ERJ-2RKF6811X
47	3	R9, R22, R24	Resistor, 2.00k, 1/16W, 1%	CRCW04022K00FKED
48	1	T1	Transformer, bias	Custom Coils, CCI 7082
49	1	T2	Transformer, 5:2	Ferrox cube, ER18/3/10-3F35-A630
50	1	U1	I.C., PWM controller	Texas Instruments, LM5030MM
51	1	U11	I.C., dual inverter	74LVC2G14GW,125
52	2	U13, U14	I.C., dual nor gate	SN74LVC2G02DCUR
53	1	U15	I.C., voltage reference	TL431AQDBZR,215
54	1	U17	I.C., bias controller	NCP1030DMR2G
55	4	U2, U3, U12, U16	I.C., half bridge driver	Texas Instruments, LM5113SD
56	2	U4, U10	I.C., regulator	LP2985IM5-5.0/NOPB
57	1	U5	I.C., uController	PIC10F222T-I/OT
58	1	U6	I.C., opamp	LMV651MG/NOPB
59	1	U8	Isolator, passive	IL611-1E
60	1	U9	Isolator, opto	PS2911-1-F3-A
61	4	X1, X2, X3, X4	Stand-offs	KEYSTONE, 5062-2
62	0	C39, C42	Capacitor, DNP	
63	0	D6, D7	Diode, DNP	
64	0	J9	Header, DNP	

# Demonstration Board – EPC9102 Schematic

Rev. 1.0

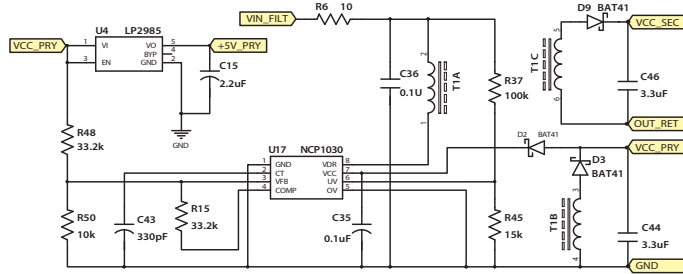

**Auxiliary Supply**

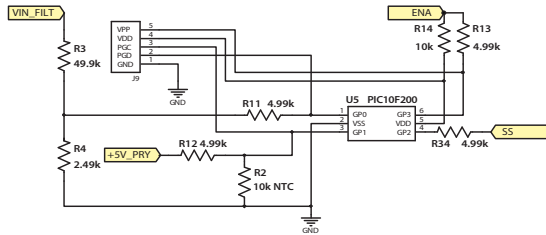

**Control**

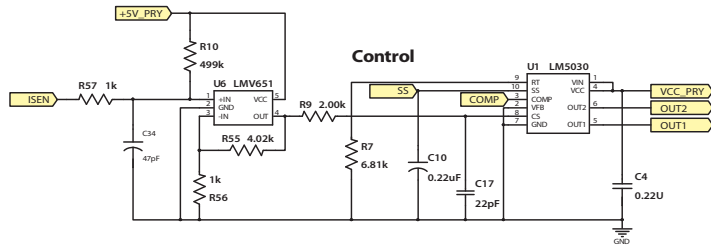

**Feedback**

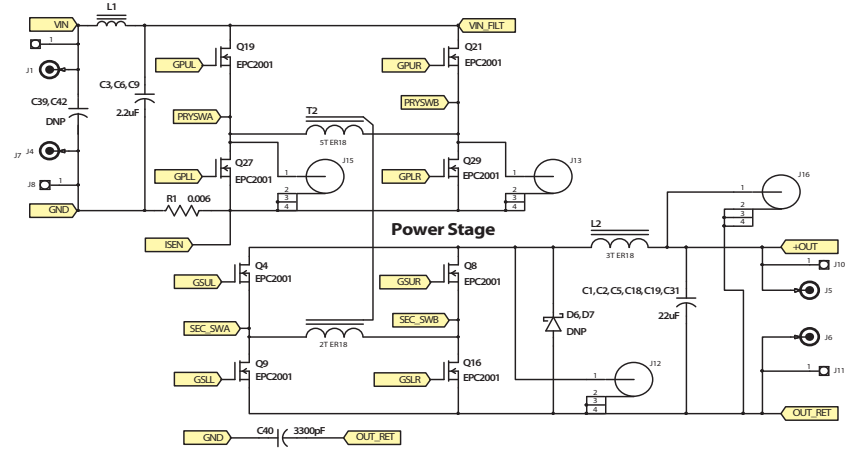

**Power Stage**

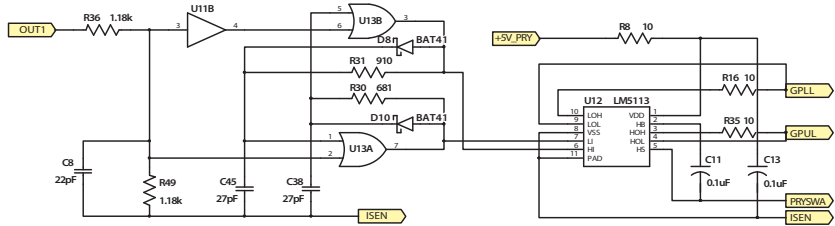

**Primary Gate Drives**

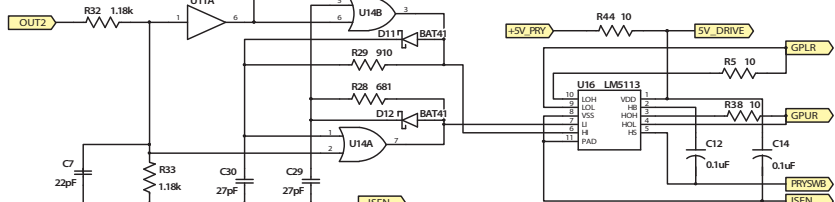

**Secondary Gate Drives**

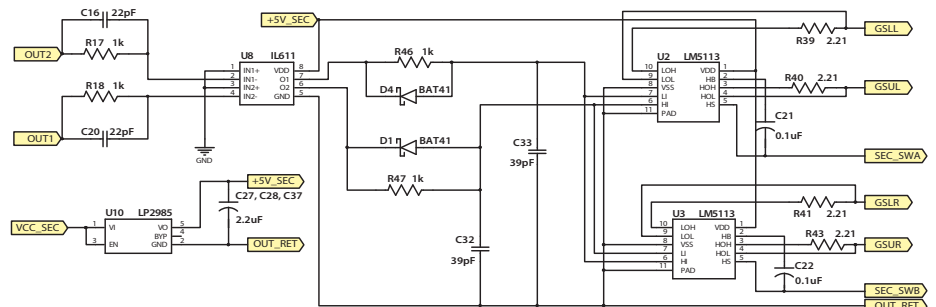

**Secondary Gate Drives**

## Contact us:

[www.epc-co.com](http://www.epc-co.com)

### Renee Yawger

#### WW Marketing

Office: +1.908.475.5702

Mobile: +1.908.619.9678

[renee.yawger@epc-co.com](mailto:renee.yawger@epc-co.com)

### Stephen Tsang

#### Sales, Asia

Mobile: +852.9408.8351

[stephen.tsang@epc-co.com](mailto:stephen.tsang@epc-co.com)

### Bhasy Nair

#### Global FAE Support

Office: +1.972.805.8585

Mobile: +1.469.879.2424

[bhasy.nair@epc-co.com](mailto:bhasy.nair@epc-co.com)

### Peter Cheng

#### FAE Support, Asia

Mobile: +886.938.009.706

[peter.cheng@epc-co.com](mailto:peter.cheng@epc-co.com)



EPC Products are distributed exclusively through Digi-Key.

[www.digikey.com](http://www.digikey.com)

### Demonstration Board Notification

The EPC9102 board is intended for product evaluation purposes only and is not intended for commercial use. As an evaluation tool, it is not designed for compliance with the European Union directive on electromagnetic compatibility or any other such directives or regulations. As board builds are at times subject to product availability, it is possible that boards may contain components or assembly materials that are not RoHS compliant. Efficient Power Conversion Corporation (EPC) makes no guarantee that the purchased board is 100% RoHS compliant. No Licenses are implied or granted under any patent right or other intellectual property whatsoever. EPC assumes no liability for applications assistance, customer product design, software performance, or infringement of patents or any other intellectual property rights of any kind.

EPC reserves the right at any time, without notice, to change said circuitry and specifications.