

THIS DRAWING IS UNPUBLISHED. RELEASED FOR PUBLICATION
 © COPYRIGHT - By - ALL RIGHTS RESERVED.

LOC	DIST	REVISIONS					
AF	50	P	LTR	DESCRIPTION	DATE	DWN	APVD
		C1		REVISED PER ECR-13-005529	05APR13	KH	CJ

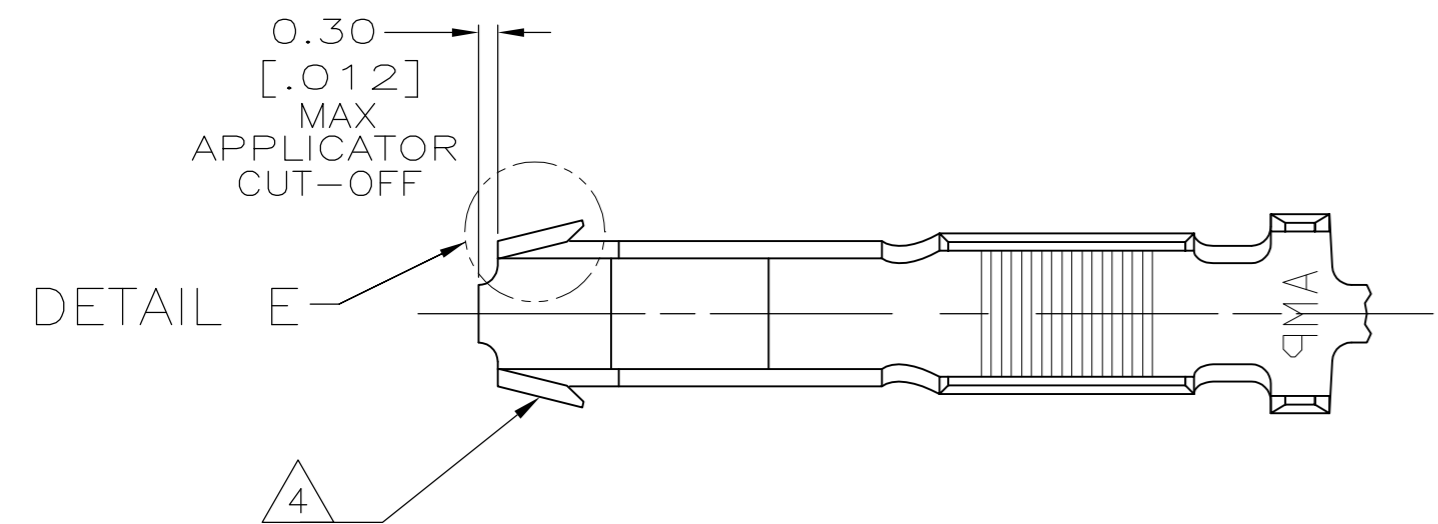

- CONTINUOUS STRIP ON REELS WITH TERMINALS LOCATED ON 23.75±0.08 [.935±.003] CENTERS.
- MEASURE CRIMP HEIGHT IN THIS AREA.
- FORMULA TO CALCULATE CRIMP HEIGHT:

$$X = \frac{Y + 15200}{238100} \quad Y = \text{CMA}$$

$$X = \text{CRIMP HEIGHT}$$
- HIGH RETENTION FEATURE.

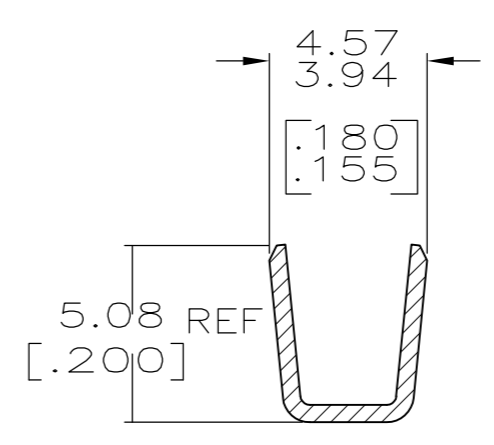
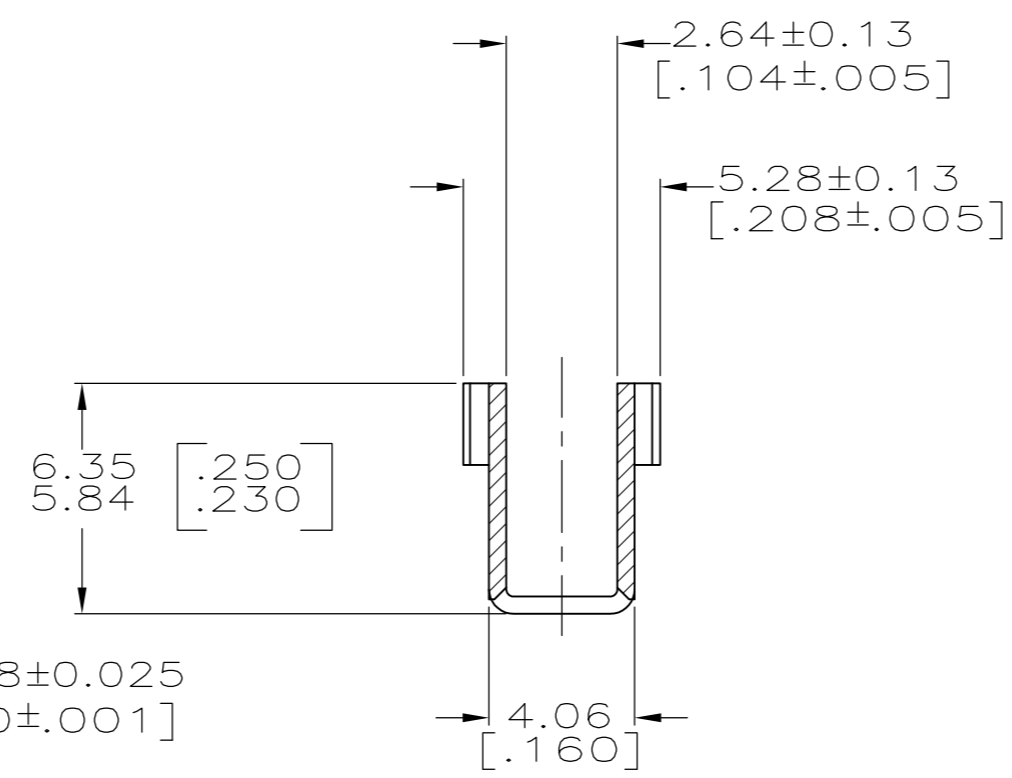
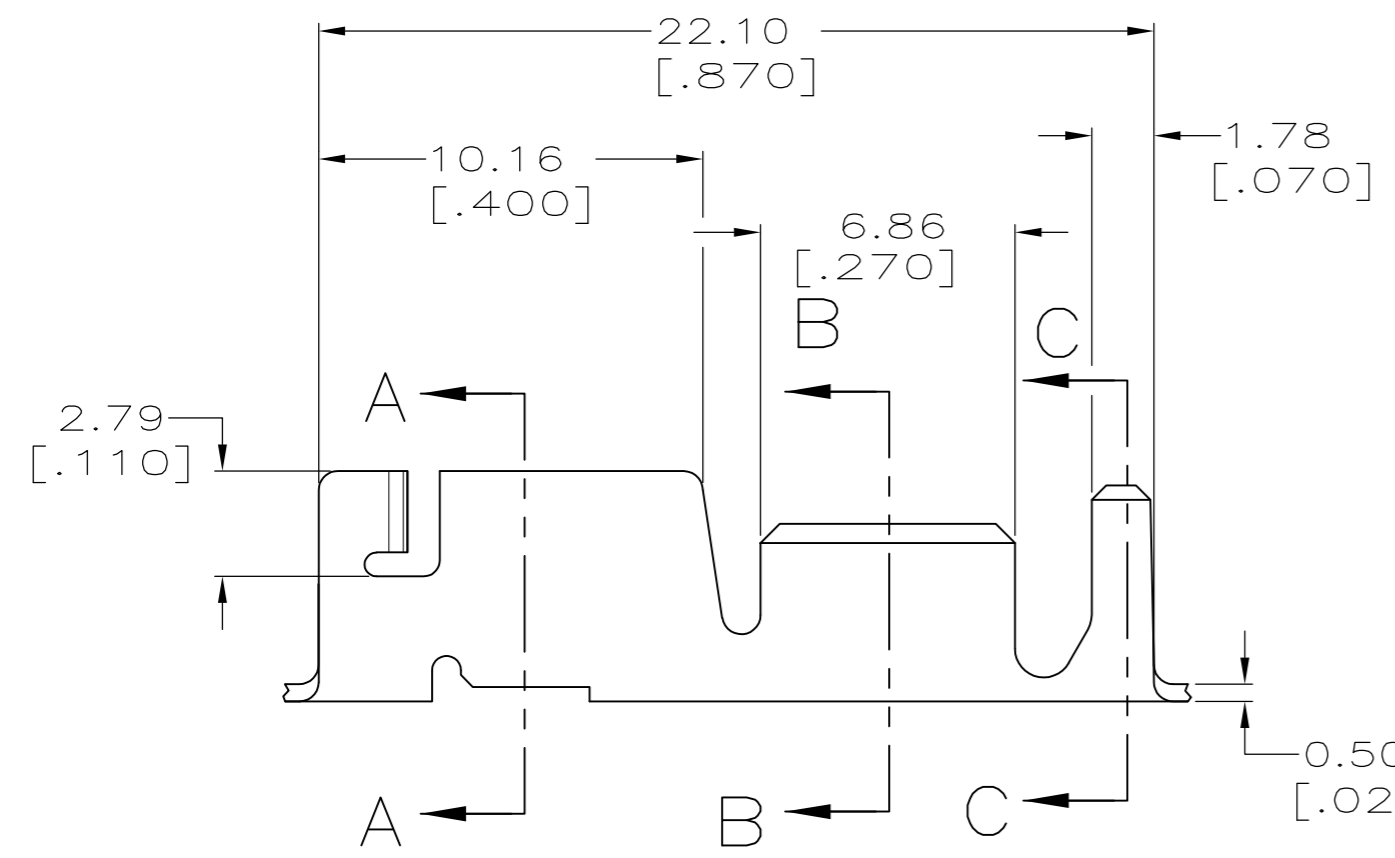

SECTION B-B

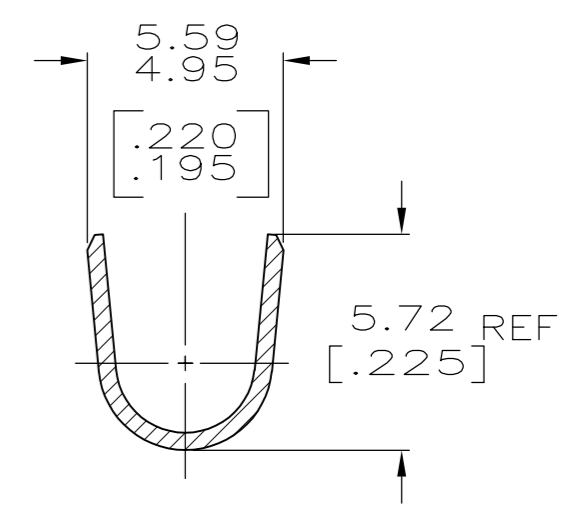

SECTION C-C

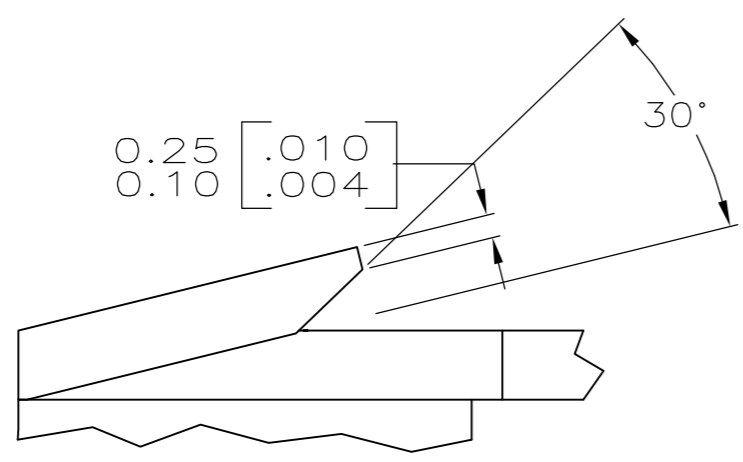

DETAIL E
SCALE 20:1

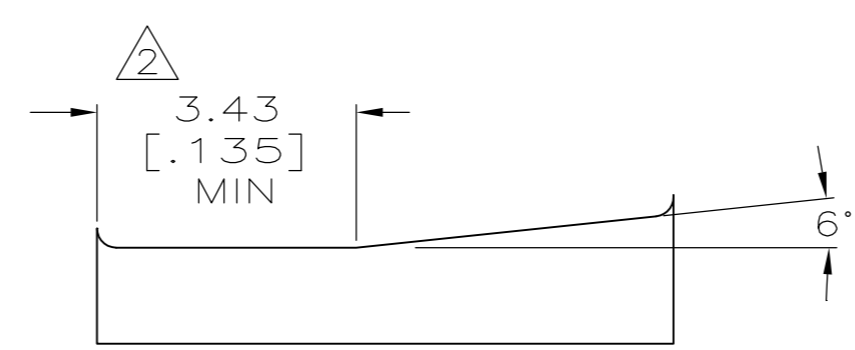

CRIMP CONFIGURATION

2.29-4.32 DIA [.090-.170]	4000-8500 CMA	1217672-1
INSULATION RANGE	WIRE RANGE	PART NUMBER

THIS DRAWING IS A CONTROLLED DOCUMENT.		DWN JR RUTH 29JUN01		
DIMENSIONS: mm [INCHES]		CHK G PORTA 29JUN01		
TOLERANCES UNLESS OTHERWISE SPECIFIED:		APVD G PORTA 29JUN01	NAME	
0 PLC ± -	1 PLC ± -	PRODUCT SPEC	RECEPTACLE, CLUSTER PIN, AMPLIVAR™ 3.18[.125] DIA	
2 PLC ± 0.25 [.010]	3 PLC ± -	APPLICATION SPEC	SIZE	CAGE CODE
4 PLC ± -	ANGLES ± -	114-2019	A2	00779
MATERIAL H03 PHOSPHOR BRONZE	FINISH POST TIN	WEIGHT -	DRAWING NO C=1217672	RESTRICTED TO -
CUSTOMER DRAWING		SCALE 5:1	SHEET 1 of 1	REV C1