

Apr.1.2017 Copyright 2017 HIROSE ELECTRIC CO., LTD. All Rights Reserved.

COUNT	DESCRIPTION OF REVISIONS	BY	CHKD	DATE	COUNT	DESCRIPTION OF REVISIONS	BY	CHKD	DATE
2	DIS-H-000773	E-D	H.V	06.02.09					

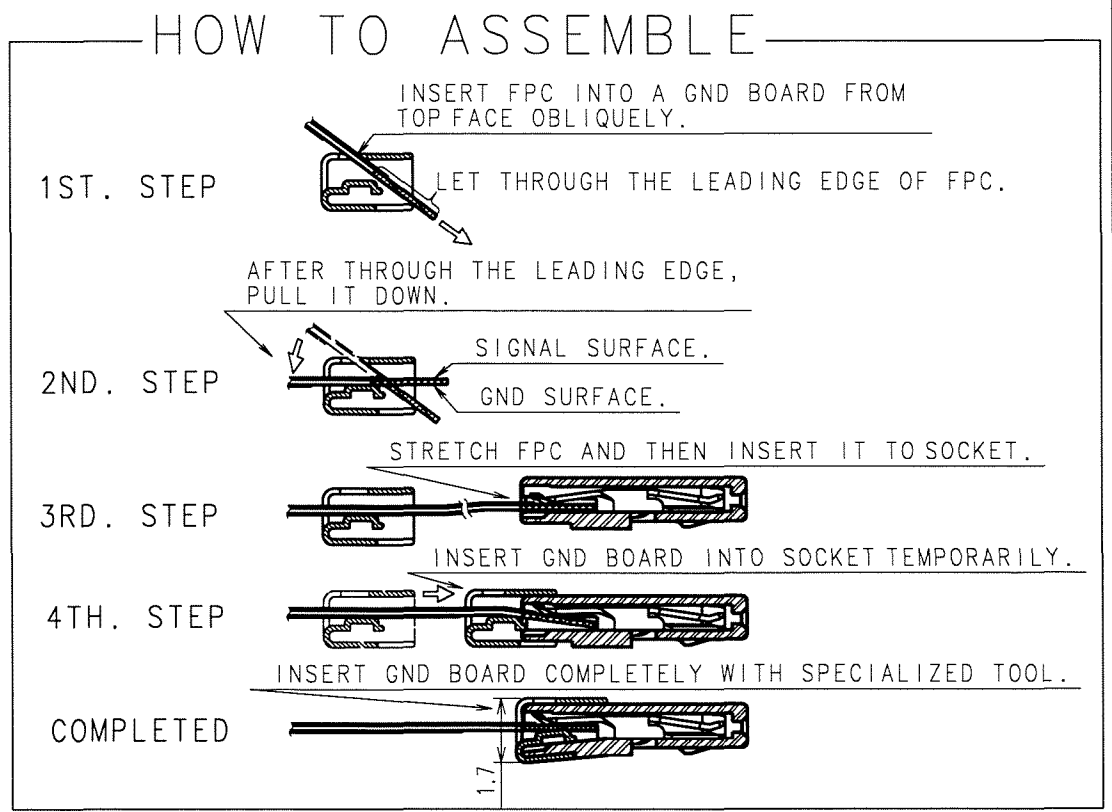

- NOTE 1: TRAY PACKAGING. (100 PCS)
 2: GND BOARD AND SOCKET, EACH SHOULD BE TREATED AS A INDIVIDUAL PRODUCT, AND BE SUPPLIED INDIVIDUALLY. (GND BOARD: DF19G-20S-1F-GND(05)/CL685-0010-3-05)
 3: IF IT'S NEEDED TO CONNECT SIGNAL SURFACE AND GND, IT MUST BE DONE BY THROUGH HOLE ON FPC.
 4: USE SPECIALIZED TOOL TO ASSEMBLE FPC.
 5: INSERTION AND WITHDRAWAL OF CONNECTOR SHALL BE MADE PERPENDICULAR TO MATING SURFACE.
 6: THIS PRODUCT IS NOT INTENDED TO HAVE ANY STRAIN ON THE CONDUCTORS IN SUCH INSTANCE AS CLOSE-OPEN MOTION OF NOTEBOOK COMPUTER.
 7: BEND RADIUS OF FPC SHALL BE AS SPECIFIED BY THE FPC MANUFACTURER. BENDING POSITION TO BE AS SHOWN BELOW.

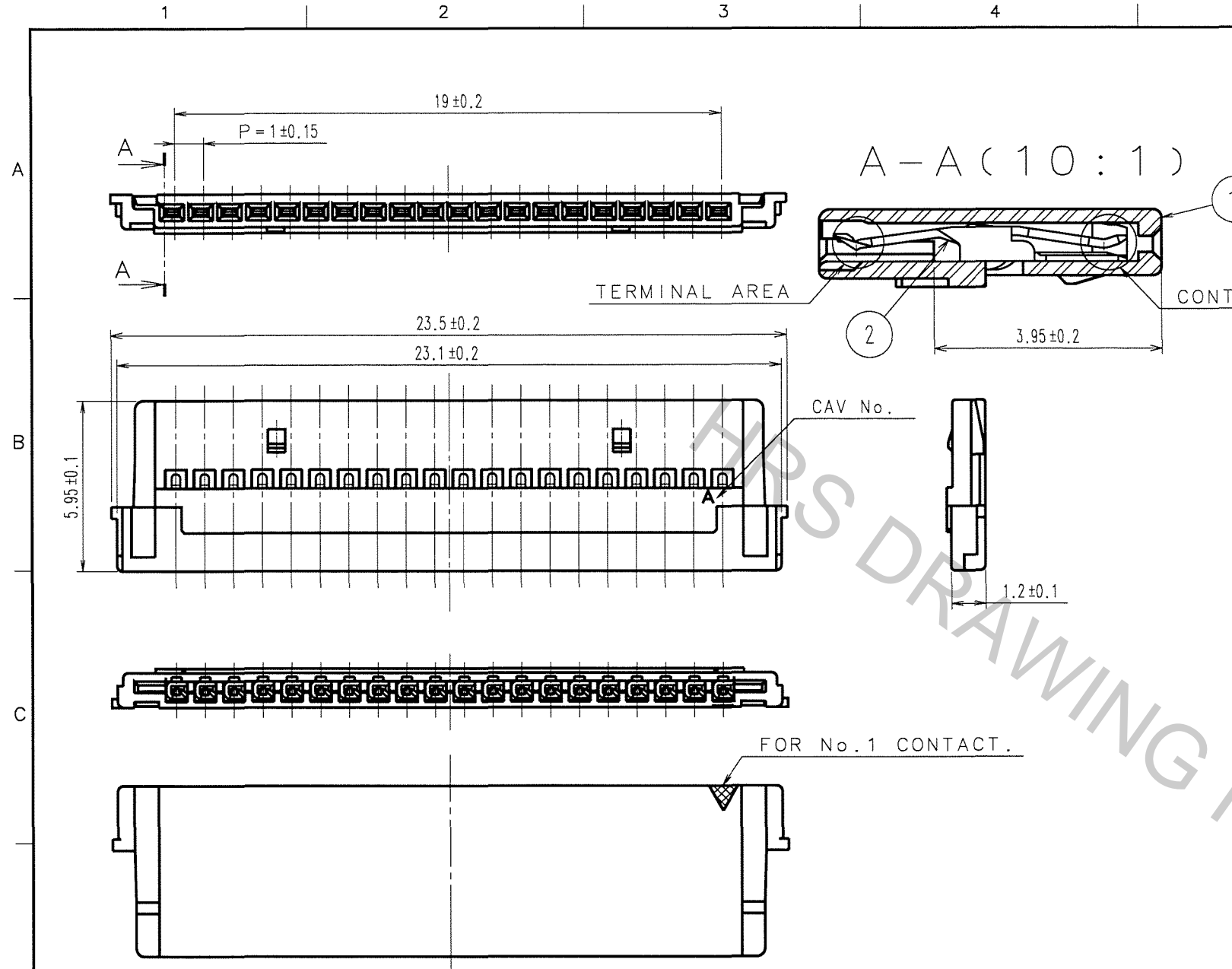
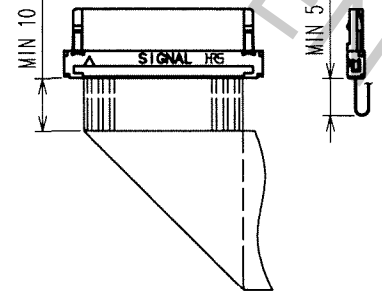

RECOMMENDED PATTERNS OF FPC(10:1)

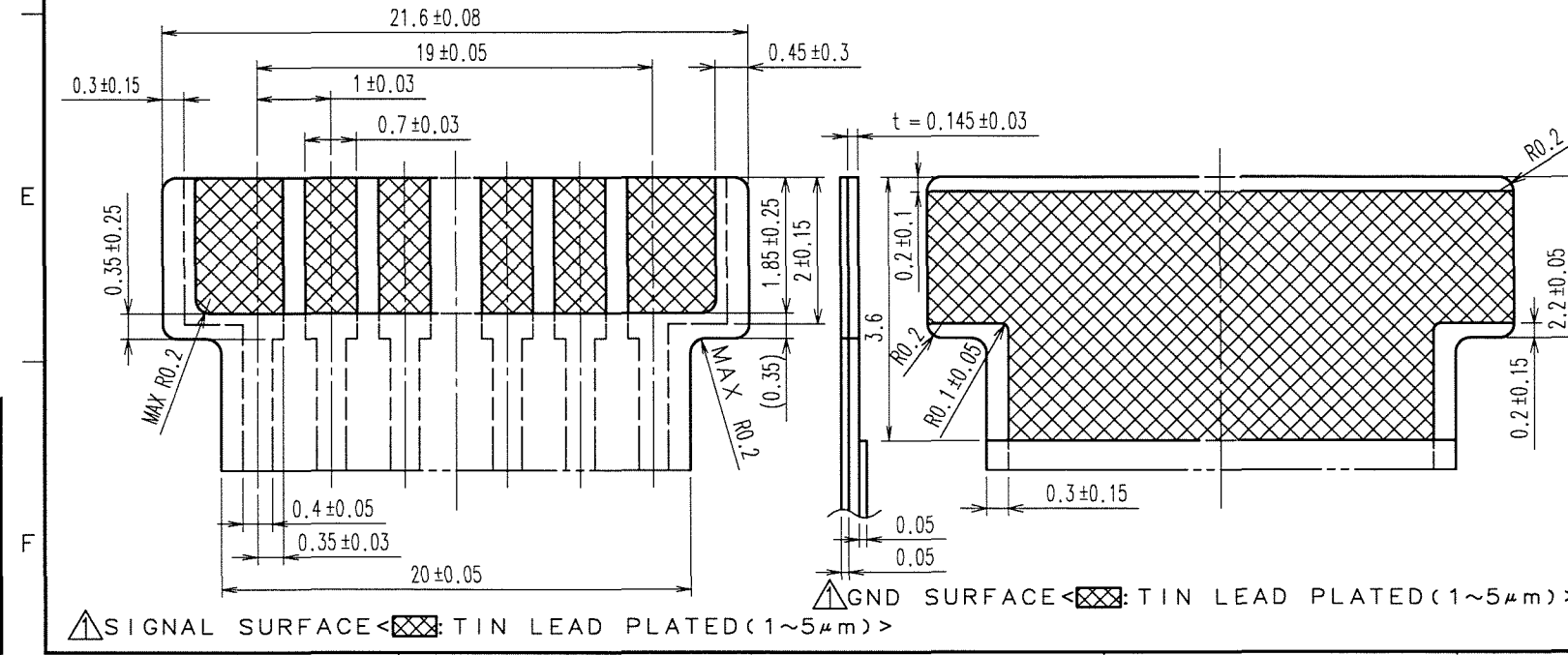

1	POLYAMIDE	UL94V-0, GRAY	2	PHOSPHOR BRONZE	CONTACT AREA: GOLD PLATED 0.1µm min CONTACT AREA: TIN PLATED 1µm min UNDER PLATED: NICKEL PLATED 0.5µm min
NO.	MATERIAL	FINISH, REMARKS	NO.	MATERIAL	FINISH, REMARKS
CODE NO. (OLD) CL?	DRAWN A.Miyazaki		DESIGNED T.Kumazawa	CHECKED H.Umehara	APPROVED T.Oma
	05.10.31		05.11.01	05.11.01	05.11.02
SCALE 5 : 1	DRAWING NO. EDC3-162454-02		PART NO. DF19G-20S-1F(05)		
UNITS mm	HRS HIROSE ELECTRIC CO., LTD.		CODE NO. CL685-0009-4-05		1/1