

PART NUMBER	REV	FIRST USED
680362-1	C	122500-1
680362-2	C	565435-5

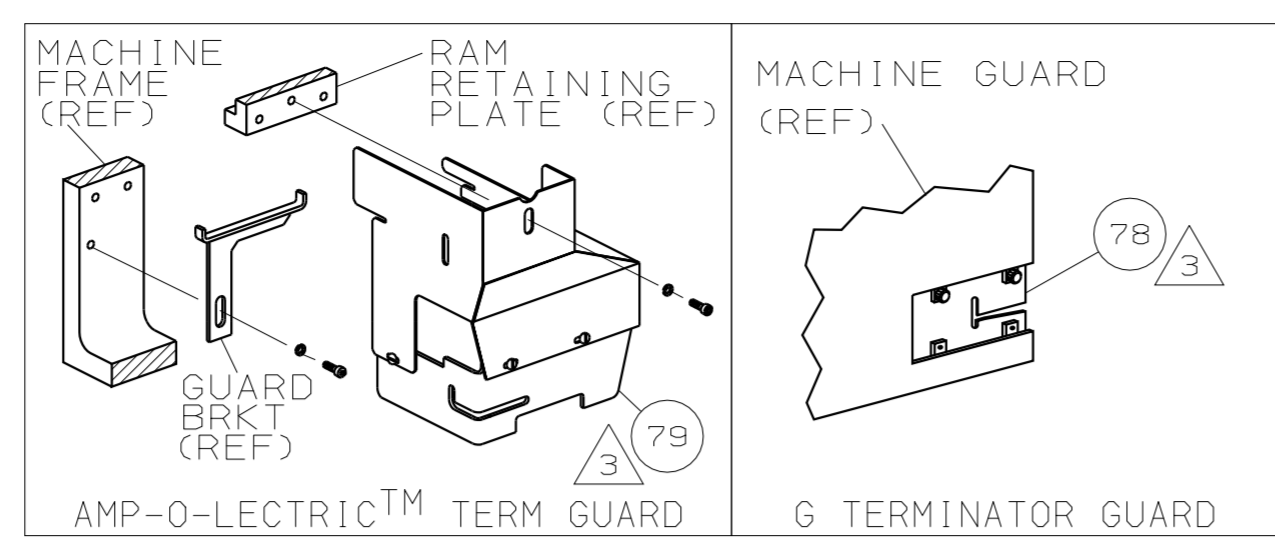

TERMINAL NAME: .250(6,3) SERIES FLAG POSITIVE LOCK RECEPTACLE			
965972			
PAD LTR	CRIMP HEIGHT	WIRE SIZE	
A	.076 ±.002 [1.93 ±0.05mm]	2.5mm ²	
B	.074 ±.002 [1.88 ±0.05mm]	2.0mm ²	
C	.065 ±.002 [1.65 ±0.05mm]	1.5mm ²	
D	.059 ±.002 [1.51 ±0.05mm]	1mm ²	
CRIMP	SIZE	TYPE	RANGE
WIRE	.110 [2.79mm]	F	1mm ² -2.5mm ²
INSUL	.160 [4.06mm]	F	3mm-4.3mm
WIRE STRIP LENGTH	TERM APPL SPEC	FEED	APPL INSTRUCTION
-	NONE	.787	408-8039
			SET UP GAGE LAYOUT
			L1820

-1	LEADMAKER & BENCH MODEL G			MECH POST FEED		
-2	BENCH MODEL K			MECH POST FEED		
1	1	-	A	22594-8	NUT, HEX	70
1	1	-	B	240628-1	PLATE, ADJ	69
1	1	-	B	240626-1	SHAFT, PIVOT	68
1	1	-	B	240633-1	BUSHING	67
1	1	-	A	455680-1	LEVER, INTERMEDIATE	66
1	1	-	B	240629-1	BLOCK, PIVOT	65
1	1	-	A	240632-2	SCR, ADJ	64
1	1	-	B	240659-3	PIN, CAM ROLLER	63
1	1	-	B	240658-1	CAM, ROLLER	62
1	1	-	B	454398-1	ROD, FEED	61
						60
1	1	-	C	454220-1	CAP, RAM	59
1	1	-	C	662633-1	HOUSING	58
						57
						56
1	1	-	B	240624-1	PIN, FEED FINGER	55
1	1	-	B	691499-1	SPRING, FEED FINGER	54
1	1	-	B	224716-2	FINGER, FEED	53
1	1	-	B	240634-1	LEVER, TERMINAL	52
1	1	-	A	690541-1	HOLDER, FEED FINGER	51
						50
						49
1	-	-	B	690501-3	CAM, POST FEED 1 1/8 ST	48
-	1	-	B	690501-4	CAM, POST-FEED 1 5/8 ST	47
						46
1	1	-	A	690191-1	PLUG, NYLON	45
1	1	-	C	662618-1	RAM	44
1	1	-	A	690125-1	WASHER, LAMINATED	43
1	1	-	A	690124-1	WASHER, RAM	42
1	1	-	A	7-21002-9	BOLT, CRIMPER(5/16-24x1.00)	41
1	1	-	A	23241-6	BALL, STEEL	40
1	1	-	A	690170-1	SPRING, COMPRESSION	39
1	1	-	C	690142-1	DISC, INSULATION	38
1	1	-	D	354777-1	WIRE DISC, PLASTIC	37
1	1	-	A	22480-5	WASHER, SPRING	36
1	1	-	B	690212-1	POST, RAM	35
						34
						33
1	1	-	B	662655-1	BLOCK, BASE	32
						31
						30
1	1	-	B	240793-1	LEVER, DRAG RELEASE	29
						28
1	1	-	A	662658-1	STRIPPER	27
1	1	-	C	662617-1	PLATE, BASE	26
						25
1	1	-	B	662656-1	PLATE, STRIP GUIDE	24
						23
2	2	-	A	1-22284-0	SPRING, DRAG	22
						21
1	1	-	A	240792-1	DRAG, STOCK	20
1	1	-	B	662657-1	GUIDE, STRIP (REAR)	19
1	1	-	C	690438-1	GUIDE, STRIP (FRONT)	18
1	1	-	A	454178-1	GUIDE, FEED ROD	17
1	1	-	A	4-22284-9	SPRING, FEED RETURN	16
						15
2	2	-	B	455888-4	SPACER, CRIMPER	14
						13
1	1	-	A	6-22279-2	SPRING, COMPRESSION	12
1	1	-	B	690461-1	STOP, SHEAR	11
1	1	-	C	662628-1	PLATE, SHEAR	10
1	1	-	C	662631-1	SHEAR.FLOATING	9
1	1	-	D	662626-1	ANVIL	8
1	1	-	B	662630-1	BLADE, SLUG	7
1	1	-	B	662632-1	DEPRESSOR, SHEAR	6
1	1	-	B	662629-1	BLADE, SLUG	5
1	1	-	B	238009-1	SPACER, BLOCK CRIMPER	4
1	1	-	C	8-683453-1	CRIMPER, INSULATION	3
1	1	-	B	455888-7	SPACER, CRIMPER	2
1	1	-	C	4-456408-2	CRIMPER, WIRE	1

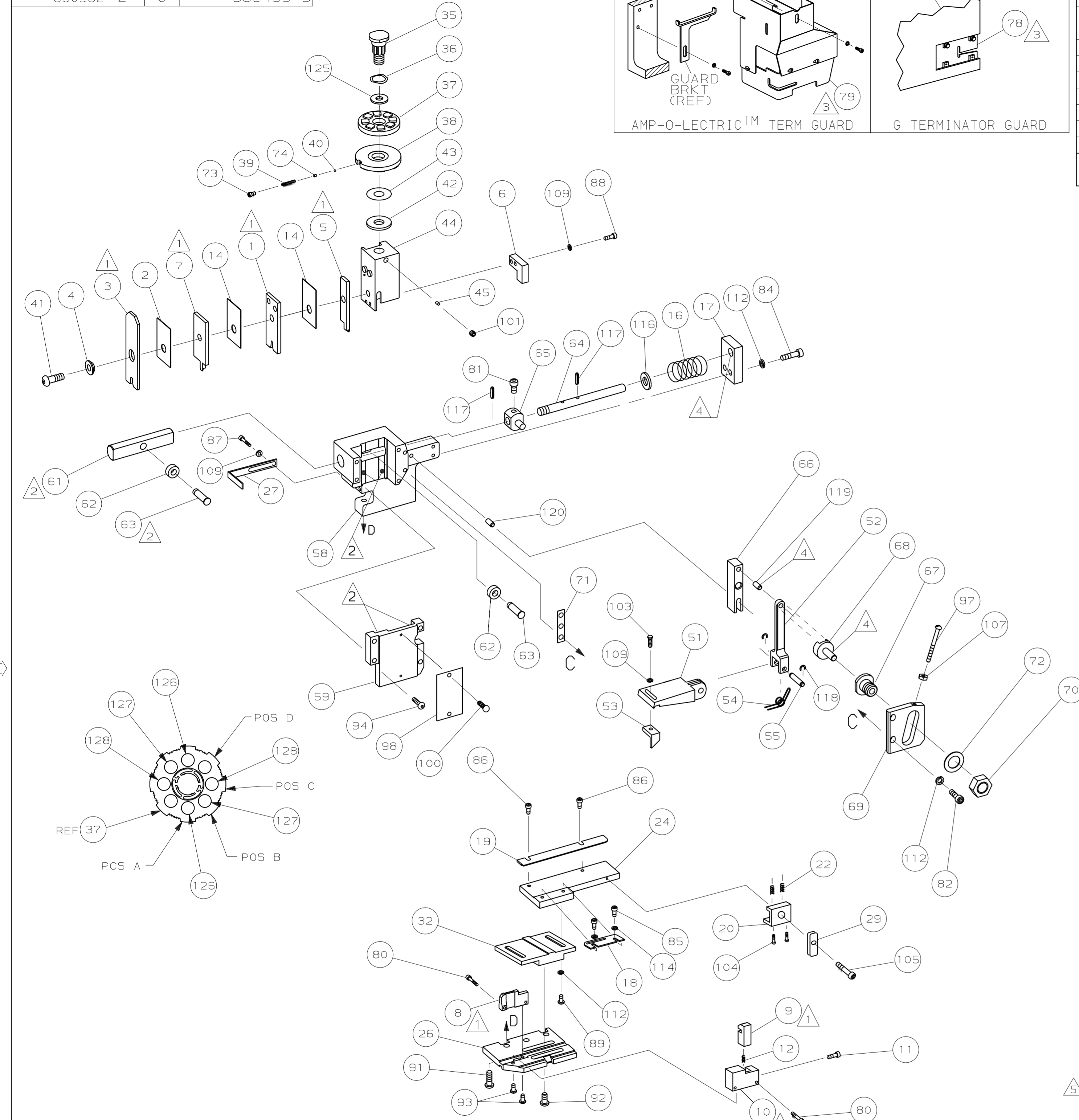

QTY	REV	U/M	DWG SIZE	PART NO	DESCRIPTION	ITEM NO
2	2	-	C	9-354778-7	PIN, WIRE DISC (.2980)D	129
2	2	-	C	8-354778-3	PIN, WIRE DISC (.2910)C	128
2	2	-	C	6-354778-5	PIN, WIRE DISC (.2820)B	127
2	2	-	C	6-354778-1	PIN, WIRE DISC (.2800)A	126
1	1	-	A	986950-1	WASHER, FLAT PRECISION	125
1	1	-	A	217238-1	GENERAL INSTRUCTION PACKAGE	124
1	1	-	-	4088039	EF APPL INST 408-8039	123
						122
						121
1	1	-	A	1-21030-7	PIN,DOWEL (Ø.187x1.50)HSG	120
1	1	-	A	1-21030-1	PIN,DOWEL (Ø.187x.50)LEVER	119
2	2	-	A	21045-3	RING,RET "C" (Ø.187)FD PIN	118
2	2	-	A	5-21028-1	PIN,STD SPRING (Ø.12)FD ADJ ROD	117
1	1	-	A	21899-4	WASHER,FLAT (Ø5/16)SCR ADJ	116
						115
2	2	-	A	21024-2	WASHER,LOCK (NO.4)FT ST GDE	114
6	6	-	A	21024-5	WASHER,LOCK (NO.10)FD ROD GDE	112
						111
						110
3	3	-	A	21024-4	WASHER,LOCK (NO.8)SHEAR BL	109
						108
1	1	-	A	21018-5	NUT, HEX (6-32)FD ADJ PL	107
						106
1	1	-	A	22353-8	SCR,SHLD (Ø.187x.25)DRAG LEVER	105
2	2	-	A	3-21002-0	SCR,BHC (10-32x.88)DRAG	104
1	1	-	A	2-22603-0	SCR, HEX HD (8-32x.31)FD FINGER	103
						102
1	1	-	A	21009-2	SCR,SKT SET (1/4-20x.25)RAM	101
2	2	-	A	21017-2	SCR,DRIVE (#2x.19) ID PLATE	100
1	1	-	A	1-21002-7	SCR,BHC (6-32x.38)CAM	99
1	1	-	B	461264-1	PLATE, IDENTIFICATION	98
1	1	-	A	6-23715-5	SCR,PAN HD (6-32x1.50)FEED ADJ	97
						96
						95
4	4	-	A	2-21002-9	SCR,BHC (10-32x.75)HSG CAP	94
2	2	-	A	22733-8	SCR,BHC (8-32x.38 LW)ANVIL	93
4	4	-	A	3-21002-3	SCR,BHC (1/4-20x.50)ST GD PL	92
3	3	-	A	2-22733-8	SCR,BHC (1/4-20x.62)BASE PL	91
						90
2	2	-	A	3-21000-4	SCR,SHC (10-32x.38)STRIP GUIDE	89
2	2	-	A	2-21000-6	SCR,SHC (8-32 x .50)	88
2	2	-	A	2-21000-5	SCR,SHC (8-32x.38)SLUG BLADE	87
2	2	-	A	2-21002-2	SCR,BHC (8-32x.50)R ST GUIDE	86
2	2	-	A	1-21000-3	SCR,SHC (4-40x.25)F ST GUIDE	85
2	2	-	A	3-21000-7	SCR,SHC (10-32x.75)FEED ROD GDE	84
						83
2	2	-	A	3-21000-6	SCR,SHC (10-32x.62)FEED ADJ PL	82
1	1	-	A	3-21000-4	SCR,SHC (10-32x.38)PIVOT BLOCK	81
2	2	-	A	2-21000-2	SCR,SHC (6-32x.75)SHEAR PL	80
REF	-	-	A	455745-1	GUARD, WINDOW	79
-	REF	-	A	679532-1	INSERT, GUARD	78
						77
						76
						75
1	1	-	A	690603-1	SPRING, ASSIST	74
1	1	-	A	23030-1	SCR,SKT CAP (6-32x.25)CP DSC	73
1	1	-	A	458109-1	WASHER, FLAT (SPECIAL)	72
1	1	-	A	690517-1	SPACER	71

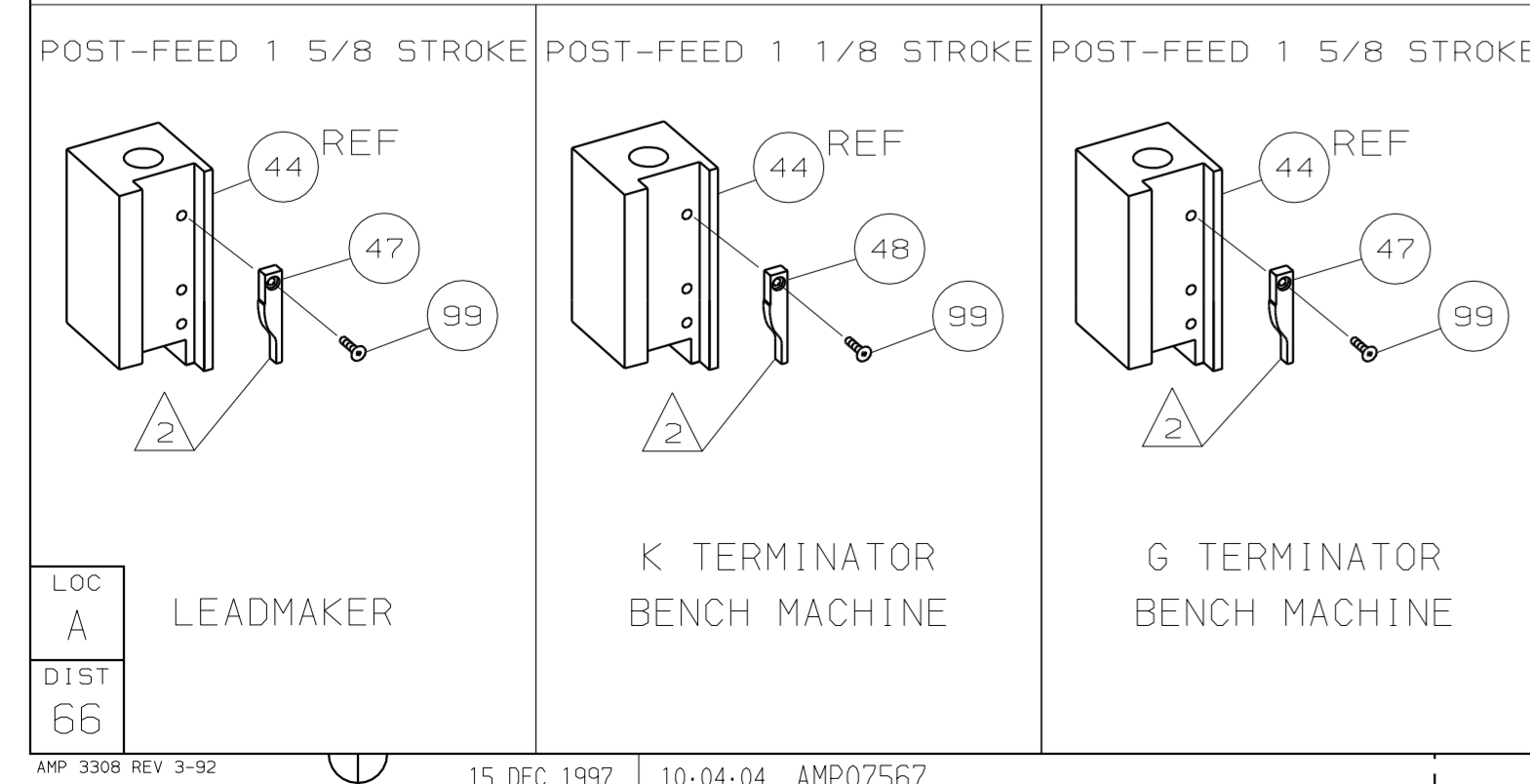

- 1 RECOMMENDED SPARE PARTS.
- 2 GREASE LIGHTLY.
- 3 GUARD MUST BE IN PLACE WHEN OPERATING APPLICATOR IN A BENCH MACHINE.
- 4 LUBRICATE DAILY USING NO. 20 MACHINE OIL.
- 5 ITEM 78 USED WITH G TERMINATOR ONLY.

QTY	REV	U/M	DWG SIZE	PART NO	DESCRIPTION	ITEM NO
-2	-1	U/M	DWG SIZE	PART NO	DESCRIPTION	ITEM NO
PARTS LIST						
C	0150-8177-97	TB	12-97			
B	0150-7595-97	TB	3/97			
A	RELEASED	CE	1-97			
REVISION RECORD						
P	F	L	T	R		

-2	-1	U/M	DWG SIZE	PART NO	DESCRIPTION	ITEM NO
REVISION OF EACH ASSY NO (WHEN BLANK, USE DWG REVISION)						
PARTS LIST						
MATL	-	HT TR	-	FIN	-	-
DIMENSIONS IN INCHES. DO NOT SCALE PRINT.						
TOLERANCES UNLESS OTHERWISE SPECIFIED:						
2 PLC DEC ±						
3 PLC DEC ±						
4 PLC DEC ±						
ANGLES ±						
SURF TEXTURE: ✓						
REMOVE BURRS, BREAK SHARP EDGES R.015 MAX						
DR	10-29-96	APP	11-4-96			
R.O.	WILSON	T.	ELBIN			
CHK	11-1-96	REL	-			
C.	ERISMAN					
NAME				END FEED HDM APPLICATOR		MACHINE REF
SCALE				DWG NO	680362	MINI APPL
				SHEET	1 OF 1	REV
						C

THIS DRAWING IS A CONTROLLED DOCUMENT FOR AMP INCORPORATED. IT IS SUBJECT TO CHANGE AND THE CONTROLLING ENGINEERING ORGANIZATION SHOULD BE CONTACTED FOR THE LATEST REVISION.

THIS INFORMATION IS CONFIDENTIAL AND IS DISCLOSED TO YOU ON CONDITION THAT NO FURTHER DISCLOSURE IS MADE BY YOU TO OTHER THAN AMP PERSONNEL WITHOUT WRITTEN AUTHORIZATION FROM AMP INCORPORATED, HARRISBURG, PA.