

PART NUMBER	REV	FIRST USED
567016-1	D	565435-5
567016-2	F	565435-5

SUPERSEDED BY -2

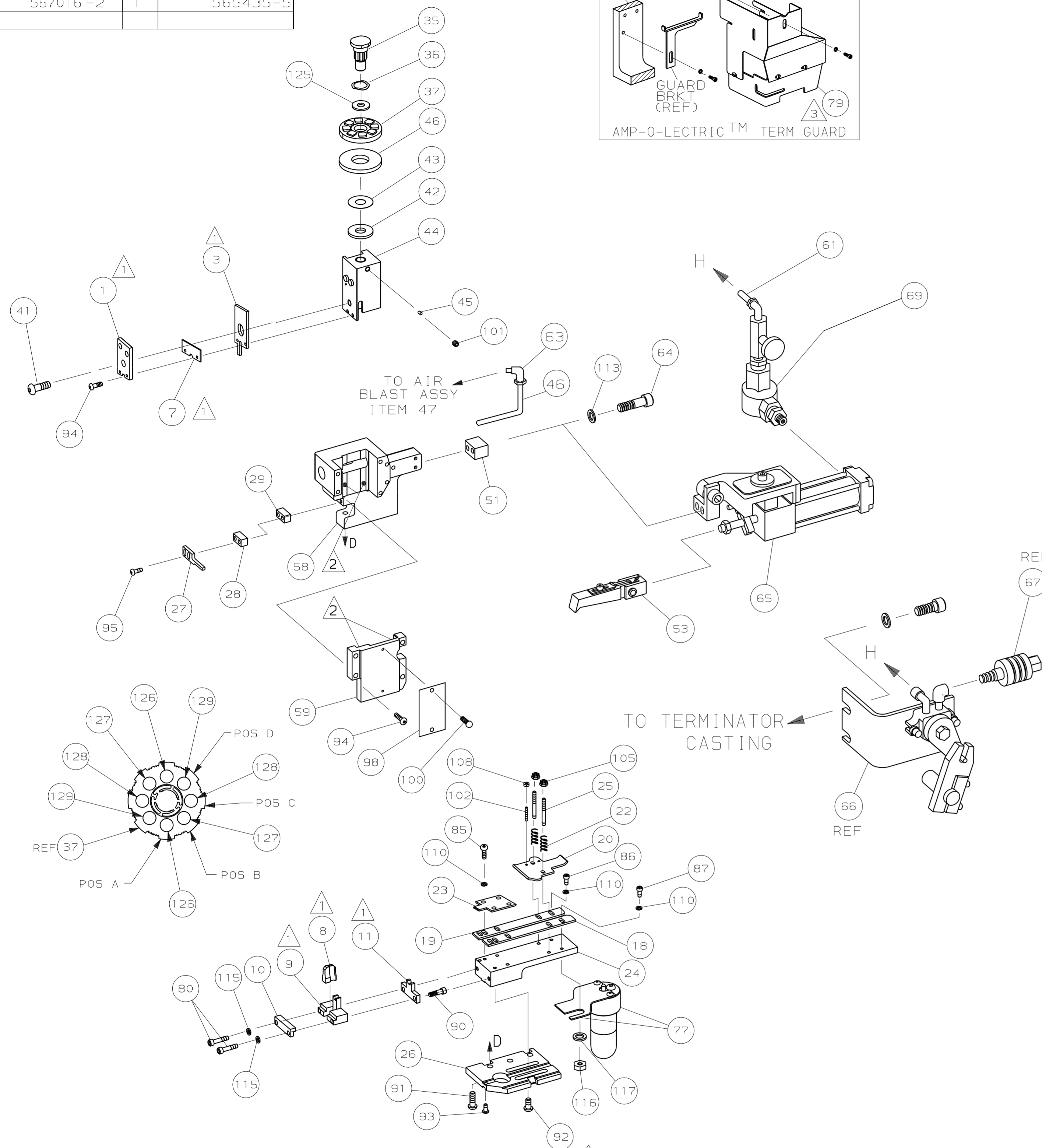
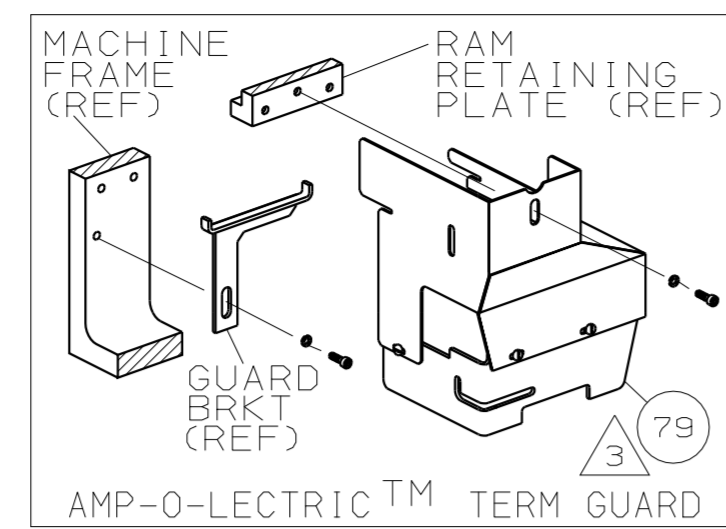

- ① RECOMMENDED SPARE PARTS.
- ② GREASE LIGHTLY.
- ③ GUARD MUST BE IN PLACE WHEN OPERATING APPLICATOR IN A BENCH MACHINE.
- ④ SEE DRAWING FOR COMPONENTS
- ⑤ RECOMMENDED SET UP WIRE  
 6200-7000 CMA; (1) 16 MAGNET  
 (1) 14 AWG  
 5200-6000 CMA; (2) 16 AWG  
 4000-5000 CMA; (1) 17 MAGNET  
 (1) 16 AWG  
 3000-3800 CMA; (2) 18 MAGNET

6. THIS APPLICATOR WILL NOT RUN IN A G OR T TERMINATING UNIT.

TERMINAL NAME: AMPLIVAR SPLICE		62308	
TERM	APPL	SPEC	114-02002

CRIMPING DATA			
PAD LTR	CRIMP HEIGHT	WIRE SIZE	
A	.089 ±.002	6200-7000 CMA	
B	.084 ±.002	5200-6000 CMA	
C	.079 ±.002	4000-5000 CMA	
D	.074 ±.002	3000-3800 CMA	
CRIMP	SIZE	TYPE	RANGE
WIRE	.140	F	3000-7000 CMA
INSUL	-	-	-
FEED	.345	APPL INST	SET UP GAGE LAYOUT
		408-8039	458638-1 -
WIRE STRIP LENGTH		-	

2	-	C	8-354778-3	PIN, WIRE DISC (.2910)D	129
2	-	C	7-354778-3	PIN, WIRE DISC (.2860)C	128
2	-	C	6-354778-1	PIN, WIRE DISC (.2800)B	127
2	-	C	5-354778-1	PIN, WIRE DISC (.2750)A	126
1	-	A	986950-1	WASHER, FLAT PRECISION	125
					124
					123
					122
					121
					120
					119
					118
1	-	A	21055-6	WASHER, FLAT (#6)LUB	117
1	-	A	21018-6	NUT, HEX (8-32)LUBE	116
2	-	A	22260-5	WASHER, FLAT (#6)RET PLATE	115
					114
4	-	A	21024-5	WASHER, LOCK (NO.10)SHEAR PL	113
					112
					111
6	-	A	21024-4	WASHER, LOCK (NO.8)SHEAR BL	110
					109
2	-	A	21018-4	NUT, HEX (4-40)DRAG	108
					107
					106
2	-	A	21022-2	NUT, HEX SL (8-32)DRAG STUD	105
					104
					103
2	-	A	4-21078-8	SKT SKT SET (4-40x.75)DRAG	102
1	-	A	21009-2	SCR, SKT SET (1/4-20x.25)RAM	101
2	-	A	21017-2	SCR, DRIVE (#2x.19)ID PLATE	100
					99
1	-	B	464249-1	PLATE, IDENTIFICATION	98
					97
					96
4	-	A	3-21000-1	SCR, SHC (8-32x1.00)STRIPPER	95
6	-	A	2-21002-9	SCR, BHC (10-32x.75)CAP	94
2	-	A	2-22733-0	SCR, SHC (10-32x.38)ANVIL	93
4	-	A	3-21002-3	SCR, BHC (1/4-20x.50)ST GD PL	92
3	-	A	2-22733-8	SCR, BHC (1/4-20x.62)HSG	91
2	-	A	1-21002-6	SCR, BHC (6-32x.25)PLATE GUIDE	90
					89
					88
1	-	A	2-21000-9	SCR, SHC (8-32x.75)STRIP GUIDE	87
1	-	A	2-21000-6	SCR, SHC (8-32x.38)STRIP GUIDE	86
4	-	A	2-21002-2	SCR, BHC (8-32x.50)STRIP GUIDE	85
					84
					83
					82
					81
2	-	A	1-21000-9	SCR, SHC (6-32x.88)SH PL	80
1	-	A	460980-2	GUARD ASSY	79
					78
					77
					76
③	-	C	1-465184-7	LUBRICATOR ASSEMBLY	75
					74
					73
					72
					71

QTY	REV	U/M	DWG SIZE	PART NO	DESCRIPTION	ITEM NO
-2	-1	U/M	DWG SIZE	PART NO	DESCRIPTION	ITEM NO
REVISION OF EACH ASSY NO (WHEN BLANK, USE DWG REVISION)						
QTY RECD PER ASSY				PARTS LIST		

1	LEADMAKER	AIRFEED
-2	BENCH MODEL K	AIRFEED

④	1	-	C	692655-5	AIR FEED VALVE ASSY	70
						68
						67
REF	-	A	24042-2	VALVE, SHUT OFF		66
④	REF	-	C	692655-6	AIR FEED VALVE ASSY	66
④	1	-	B	460277-1	AIR FEED ASSY	65
	2	-	A	4-21000-3	SCR, SHC 10-32X2.00 AIR ASSY	64
	1	-	A	22317-3	ELBOW, TUBING 1/8NPT - 1/4 T	63
						62
12.00		IN	A	27319-4	TUBING, POLY-FLO Ø.25	61
						60
	1	-	C	462926-1	CAP, RAM	59
	1	-	D	453736-1	HOUSING	58
						57
						56
						55
						54
④	1	-	B	460680-7	FEED FINGER ASSY	53
						52
	1	-	B	461690-1	SPACER, AIR FEED	51
						50
						49
						48
						47
1	-	A	455350-1	AIR BLAST ASSEMBLY		47
1	-	A	689446-2	TUBE, AIR BLAST		46
1	-	A	690191-1	PLUG, NYLON		45
1	-	C	459586-1	RAM		44
1	-	A	690125-1	WASHER, LAMINATED		43
1	-	A	690124-1	WASHER, RAM		42
1	-	A	7-21002-9	BOLT, CRIMPER (5/16-24x1.00)		41
1	-	A	690223-1	SPACER, DISC		40
						39
						38
1	-	D	354777-1	WIRE DISC, PLASTIC		37
1	-	A	22480-5	WASHER, SPRING		36
1	-	B	690212-1	POST, RAM		35
						34
						33
						32
						31
						30
1	-	B	1-690451-8	SPACER, STRIPPER		29
1	-	B	3-690451-5	SPACER, STRIPPER		28
1	-	A	460276-1	STRIPPER		27
1	-	D	459584-1	PLATE, BASE		26
2	-	A	22354-8	DRAG, STUD		25
1	-	B	462931-1	PLATE, STRIP GUIDE		24
1	-	C	462932-1	PLATE, STRIP HOLD DOWN		23
2	-	A	4-22281-1	SPRING, DRAG		22
						21
						20
1	-	A	462925-1	DRAG, STOCK		20
1	-	B	462929-1	GUIDE, STRIP (REAR)		19
1	-	C	462930-1	GUIDE, STRIP (FRONT)		18
						17
						16
						15
						14
						13
						12
①	1	-	B	459684-4	PLATE, REAR SHEAR	11
①	1	-	C	459580-1	SPACER, SHEAR PLATE	10
①	1	-	B	459583-4	PLATE, FRONT SHEAR	9
①	1	-	D	459582-8	ANVIL	8
①	1	-	B	459581-2	BLADE, SLUG	7
						6
						5
						4
①	1	-	C	459587-1	CRIMPER, INSULATION	3
						2
①	1	-	C	459585-5	CRIMPER, WIRE	1

QTY	REV	U/M	DWG SIZE	PART NO	DESCRIPTION	ITEM NO
-2	-1	U/M	DWG SIZE	PART NO	DESCRIPTION	ITEM NO
REVISION OF EACH ASSY NO (WHEN BLANK, USE DWG REVISION)						
QTY RECD PER ASSY				PARTS LIST		

LOC A  
DIST 66

DIMENSIONS IN INCHES. DO NOT SCALE PRINT.  
 TOLERANCES UNLESS OTHERWISE SPECIFIED:  
 2 PLC DEC ±.25  
 3 PLC DEC ±.  
 4 PLC DEC ±.  
 ANGLES ±.  
 SURF TEXTURE: ✓  
 REMOVE BURRS, BREAK SHARP EDGES R.015 MAX

MATL - HT TR - FIN -

DR 8/1/94 APP 8-1-94  
 D.SALTZER T.BEDDICK  
 CHK 8-1-94 REL 9/20/94  
 C.ERISMAN B. MORGAN

AMP AMP Incorporated Harrisburg, PA 17105-3608

NAME END FEED HDM APPLICATOR MACHINE REF MINI APPL  
 SCALE - DWG NO 567016 SHEET 1 OF 1 REV F

THIS DRAWING IS A CONTROLLED DOCUMENT FOR AMP INCORPORATED. IT IS SUBJECT TO CHANGE AND THE CONTROLLING ENGINEERING ORGANIZATION SHOULD BE CONTACTED FOR THE LATEST REVISION.

THIS INFORMATION IS CONFIDENTIAL AND IS DISCLOSED TO YOU ON CONDITION THAT NO FURTHER DISCLOSURE IS MADE BY YOU TO OTHER THAN AMP PERSONNEL WITHOUT WRITTEN AUTHORIZATION FROM AMP INCORPORATED, HARRISBURG, PA.